

User's Guide

GS1100 Series

Unmanaged (Plus) Gigabit Ethernet Switches

Default Login Details

LAN IP Address	http://DHCP-assigned IP or 192.168.1.3
Password	On the back label on the Switch

Version 1.00 Edition 2 06/2026

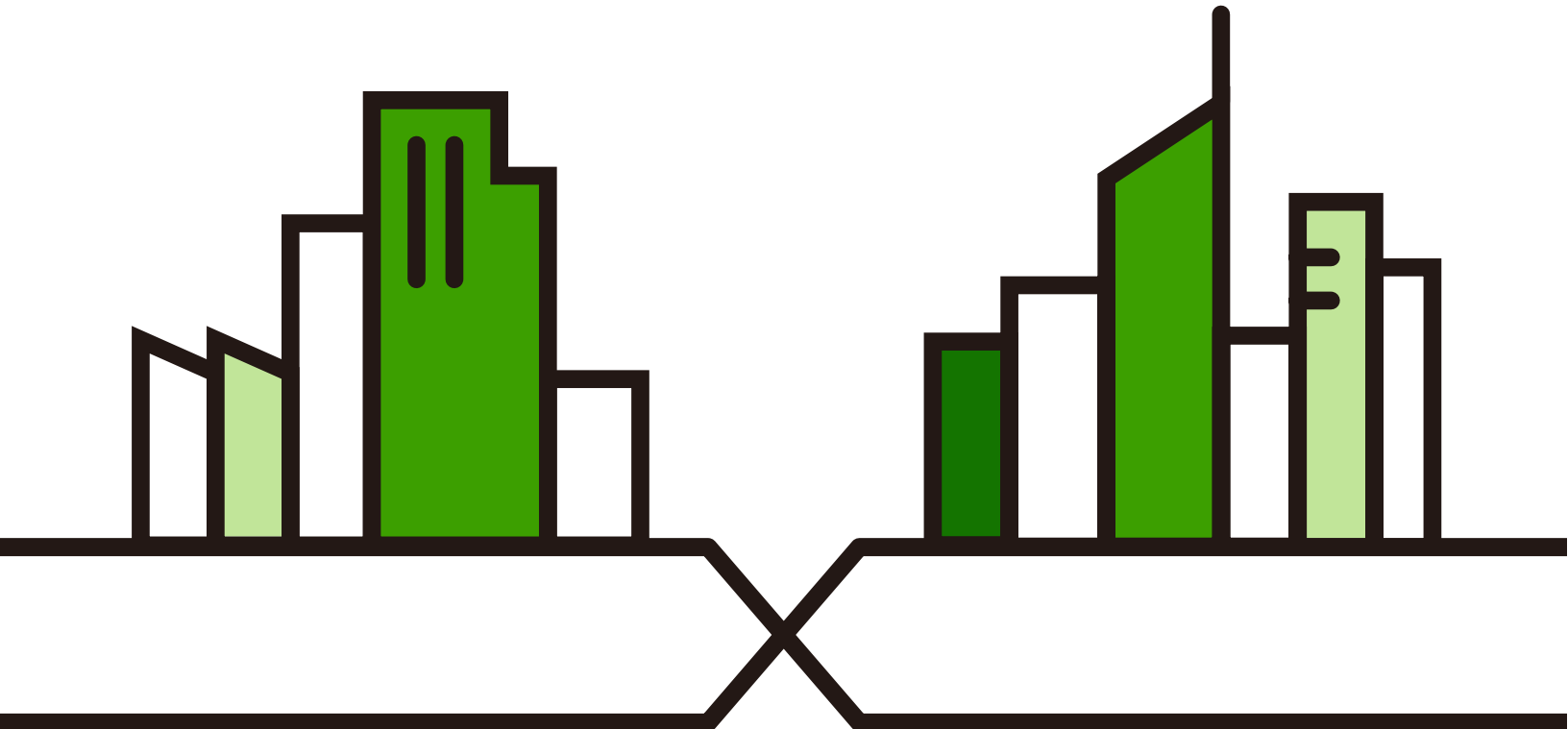

IMPORTANT!

READ CAREFULLY BEFORE USE.

KEEP THIS GUIDE FOR FUTURE REFERENCE.

Screenshots and graphics in this book may differ slightly from your product due to differences in your product firmware or your computer operating system. Every effort has been made to ensure that the information in this manual is accurate.

Related Documentation

- Quick Start Guide

The Quick Start Guide shows how to connect the Switch.

- More Information

Go to <https://community.zyxel.com/en> for product discussions.

Go to support.zyxel.com to find other information on the Switch.



Document Conventions

Warnings and Notes

These are how warnings and notes are shown in this guide.

Warnings tell you about things that could harm you or your device.











Note: Notes tell you other important information (for example, other things you may need to configure or helpful tips) or recommendations.

Syntax Conventions

- All models may be referred to as the "Switch" in this guide.
- Product labels, screen names, field labels and field choices are all in **bold** font.
- A right angle bracket (>) within a screen name denotes a mouse click. For example, **Configuration > System > Information** means you first click **Configuration** in the navigation panel, then the **System** sub menu and finally the **Information** tab to get to that screen.

Icons Used in Figures

Figures in this user guide may use the following generic icons. The Switch icon is not an exact representation of your device.

Switch 	Generic Router 	Wireless Router / Access Point 
Generic Switch 	Smart TV 	Desktop 
Laptop 	IP Camera 	Printer 
Server 		

Contents Overview

User's Guide	8
Getting to Know Your Switch	9
Hardware Installation and Connection	14
Hardware Panels	21
Web Configurator	33
Initial Setup Example	37
Tutorials	39
Technical Reference	45
System	46
Port	49
VLAN	53
Management	56
Troubleshooting	60

Table of Contents

Part I: User's Guide	8
Chapter 1	
Getting to Know Your Switch	9
1.1 Introduction	9
1.2 Features	10
1.3 Example Applications	11
1.3.1 PoE Example Application	11
1.3.2 Backbone Example Application	12
1.3.3 Bridging or Fiber Optic Uplink Example Application	12
1.4 Ways to Manage the Switch	13
1.5 Good Habits for Managing the Switch	13
Chapter 2	
Hardware Installation and Connection	14
2.1 Installation Scenarios	14
2.2 Safety Precautions	14
2.3 Desktop Placement Procedure	15
2.4 Wall Mounting	15
2.4.1 Installation Requirements	16
2.5 Mounting the Switch on a Rack	18
2.5.1 Installation Requirements	19
2.5.2 Precautions	19
2.5.3 Attaching the Mounting Brackets to the Switch	19
2.5.4 Mounting the Switch on a Rack	19
Chapter 3	
Hardware Panels	21
3.1 Front Panel	21
3.1.1 LED OFF Button	22
3.1.2 IEEE 802.3az EEE Button	22
3.1.3 Gigabit Ethernet Ports	23
3.1.4 PoE	23
3.1.5 Restore Button	24
3.1.6 SFP Slots	24
3.2 Rear Panel	26
3.2.1 Grounding	27
3.2.2 Power Connection	29

3.2.3 Kensington Lock (for UM+ model)	29
3.3 LEDs	30
Chapter 4	
Web Configurator.....	33
4.1 Overview	33
4.2 Access the Switch	33
4.3 Log in to the Web Configurator	34
4.4 Web Configurator Layout	35
4.5 Switch Lockout / Resetting the Switch	36
4.6 Logging Out of the Web Configurator	36
Chapter 5	
Initial Setup Example	37
5.1 Overview	37
5.1.1 Change the IP Address	37
5.1.2 Change the Password	38
Chapter 6	
Tutorials	39
6.1 Overview	39
6.2 Creating a VLAN and Setting Port VID	39
6.2.1 Creating a VLAN	39
6.2.2 Setting Port VID	40
6.3 Upgrade Firmware on the Switch	41
6.4 Back up a Configuration File	41
6.5 Restore Configuration	42
6.6 Power over Ethernet (PoE) Configuration	42
Part II: Technical Reference	45
Chapter 7	
System.....	46
7.1 Overview	46
7.2 System Screen	46
Chapter 8	
Port.....	49
8.1 Overview	49
8.1.1 Loop	49
8.1.2 Port Isolation	49

8.2 Port Settings	50
Chapter 9	
VLAN	53
9.1 Overview	53
9.1.1 IEEE 802.1Q Tagged VLANs	53
9.2.1 VLAN Passthrough	54
9.2.2 IEEE 802.1Q VLAN	54
Chapter 10	
Management	56
10.1 Overview	56
10.1.1 IEEE 802.3az Energy Efficient Ethernet (EEE)	56
10.2.1 Firmware Upgrade	58
Chapter 11	
Troubleshooting	60
11.1 Power, Hardware Connections, and LEDs	60
11.2 Switch Access and Login	61
11.3 Switch Configuration	63
11.4 PoE Supply	63
11.5 Improper Network Cabling and Topology	64
Appendix A Customer Support	65
Appendix B Legal Information	70
Index.....	86

PART I

User's Guide

CHAPTER 1

Getting to Know Your Switch

1.1 Introduction

GS1100 Series includes both Unmanaged (UM) Switch and Unmanaged Plus (UM+) Switch models, as listed below. The Unmanaged Plus Switch allows you to manage the Switch using the Web Configurator to configure additional features. GS1100-16 and GS1100-24E both have UM and UM+ versions. Refer to [Section 3.1 on page 21](#) to determine your switch model based on the hardware differences. Refer to the [Feature Comparison](#) table for the differences between each models.

Table 1 GS1100 Series Model List

	UNMANAGED (UM) SWITCH	UNMANAGED PLUS (UM+) SWITCH
GS1100-10HP (Revision B1)	Yes	No
GS1100-10HP (Revision A1)	Yes	No
GS1100-16	Yes	Yes
GS1100-16E	No	Yes
GS1100-16EP	No	Yes
GS1100-24	Yes	No
GS1100-24E	Yes	Yes

The Switch is a 10/100/1000 Mbps multi-port switch designed for building high-performance switched workgroup networks. The Switch is a store-and-forward device that offers low latency for high-speed networking. The Switch is for workgroups, departments, or backbone computing environments for small businesses.

The following table describes the hardware features of the Switch by model.

Table 2 Feature Comparison

PORT/SWITCH DETAILS	GS1100-10HP (REVISION B1)	GS1100-10HP (REVISION A1)
10/100/1000Base-T Ethernet ports	8	8
100/1000Base-X SFP slots	2	2
802.3at PoE ports	8	8
Max PoE Power Supply per port	30W	30W
Total PoE Power Budget	130W	130W
Physical IEEE 802.3az ON/OFF button	No, enable EEE by default	Yes
Power ON/OFF switch	No	Yes
LED OFF button	No	No
Restore button	No	No
Desktop Placement	Yes	Yes
Wall-mountable	Yes	Yes
Rack-mountable	No	No

Table 2 Feature Comparison (continued)

PORT/SWITCH DETAILS	GS1100-10HP (REVISION B1)	GS1100-10HP (REVISION A1)
Power Adapter	Yes	Yes
Power Cord	No	No
Grounding	Yes	Yes
Fan	No	No
Web Configurator Management	No	No

The following table describes the hardware features of the Switch by model.

Table 3 Feature Comparison

PORT/SWITCH DETAILS	GS1100-16	GS1100-16E	GS1100-16EP	GS1100-24E	GS1100-24
10/100/1000Base-T Ethernet ports	16	16	16	24	24
100/1000Base-X SFP slots	No	No	No	No	2
802.3at PoE ports	No	No	Yes	No	No
Max PoE Power Supply per port	No	No	30W	No	No
Total PoE Power Budget	No	No	135W	No	No
Physical IEEE 802.3az ON/OFF button	No, enable EEE by default	No, enable EEE by default	No, enable EEE by default	No, enable EEE by default	No, enable EEE by default
Power ON/OFF switch	No	No	No	No	No
LED OFF button	No (UM) Yes (UM+)	Yes	Yes	No (UM) Yes (UM+)	No
Restore button	No (UM) Yes (UM+)	Yes	Yes	No (UM) Yes (UM+)	No
Desktop Placement	Yes	No	No	Yes	No
Wall-mountable	Yes	Yes	Yes	Yes	No
Rack-mountable	Yes	No	No	Yes	Yes
Power Adapter	No	Yes	Yes	No	No
Power Cord	Yes	No	No	Yes	Yes
Grounding	No	No	No	No	No
Fan	No	No	No	Yes (UM) No (UM+)	Yes
Web Configurator Management	No (UM) Yes (UM+)	Yes	Yes	No (UM) Yes (UM+)	No

The GbE PoE ports can supply power to the connected PoE powered devices (PDs).

The SFP slots are for uplink connections. Use SFP transceivers in these slots for 100 Mbps or 1 Gbps connections to backbone Ethernet switches.

The Switch has a built-in algorithm that automatically assigns priority to received packets. It can operate in low power idle mode in compliance with IEEE 802.3az Energy Efficient Ethernet (EEE).

1.2 Features

The following are the essential features of the Switch.

- Conforms to IEEE 802.3, 802.3u, 802.3ab and 802.3x standards.
- Auto-negotiating 10/100/1000 Mbps Gigabit Ethernet (GbE) RJ-45 ports.

- Auto-sensing crossover for all 10/100/1000 Mbps Gigabit Ethernet (GbE) RJ-45 ports.
- Supports N-Way protocol for speed (10/100/1000 Mbps) and duplex mode (Half/Full) auto-detection.
- Supports store-and-forward switching.
- Supports automatic address learning.
- Supports IEEE 802.3az EEE Standard.
- Supports IEEE 802.3af and IEEE 802.3at PoE standards.
- Full wire speed forwarding rate.
- Supports IEEE 802.1p CoS (Quality of Service).
- Embedded 8K MAC address table providing 8000 MAC addresses entries. (UM)
- Embedded 16K MAC address table providing 16000 MAC addresses entries. (UM+)
- Web Configurator provides an easy-to-use web interface for Switch configuration. (UM+)
- Supports IEEE 802.1Q VLAN with up to 5 static VLAN entries. (UM+)
- Loop prevention helps detect and block network loops to maintain stable network operation. (UM+)
- Port isolation restricts direct communication between ports to improve network security. (UM+)

1.3 Example Applications

This section shows a few examples of using the Switch in various network environments. Note that the Switch in the figure is just an example Switch and not your actual Switch.

1.3.1 PoE Example Application

The following example figure shows a Switch supplying PoE (Power over Ethernet) to powered devices (PDs) such as an IP camera, a wireless router, an IP telephone and an outdoor router that are not within reach of a power outlet.

Figure 1 Powered Device Example

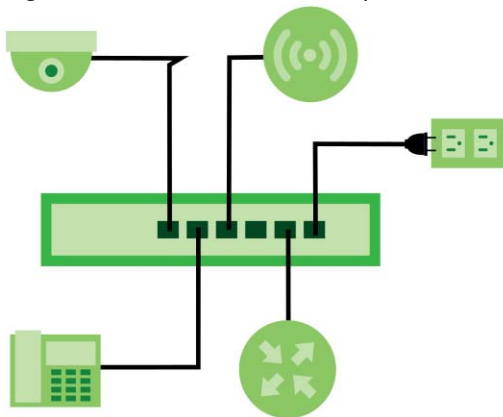

PoE ports support both the IEEE 802.3af Power over Ethernet and IEEE 802.3at High Power over Ethernet standards.

The Switch is a Power Sourcing Equipment (PSE) because it provides power through its Ethernet ports. A powered device is a device such as an access point or an IP phone, that supports PoE so that it can receive power from another device through a 10/100/1000 Mbps Ethernet port.

In the figure above, the IP camera and IP phone get their power directly from the Switch through a 10/100/1000 Mbps Ethernet cable. PoE allows installation of PDs where there are no nearby electric power outlets.

1.3.2 Backbone Example Application

The Switch is an ideal solution for small networks where rapid growth can be expected in the near future. The Switch can be used standalone for a group of heavy traffic users. You can connect computers and servers directly to the Switch's port or connect other switches to the Switch.

In this example, all computers can share high-speed applications on the server. To expand the network, simply add more networking devices such as switches, routers, computers, print servers, and so on.

Figure 2 Backbone Application

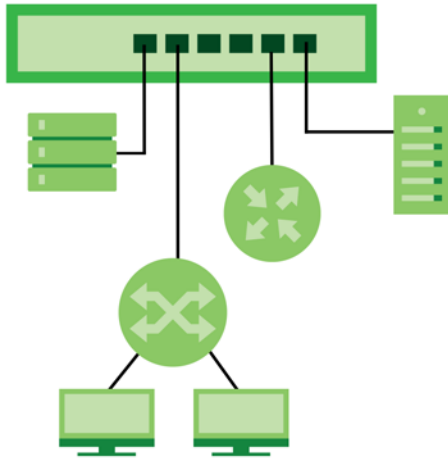

1.3.3 Bridging or Fiber Optic Uplink Example Application

In this example, the Switch connects different company departments (**RD** and **S**) to the corporate backbone. It can alleviate bandwidth contention and eliminate server and network bottlenecks. All users that need high bandwidth can connect to high-speed department servers through the Switch. You can provide a super-fast uplink connection by using a Gigabit Ethernet or SFP port on the Switch.

Figure 3 Bridging Example Application

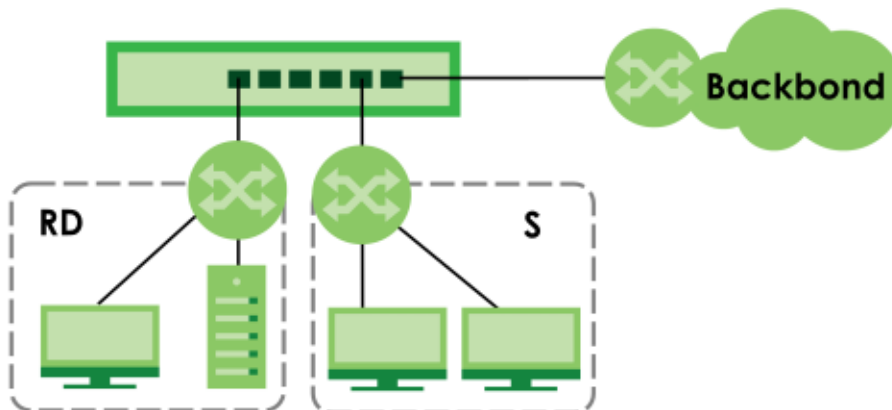

1.4 Ways to Manage the Switch

For UM+ Switch, you can use the Web Configurator with (supported) web browser for easy Switch setup and management. See [Section 4.1 on page 33](#).

1.5 Good Habits for Managing the Switch

For UM+ Switch, do the following things regularly to make the Switch more secure and to manage the Switch more effectively.

- Change the password. Use a password that is not easy to guess and that consists of different types of characters, such as numbers and letters.
- Write down the password and put it in a safe place.
- Back up the configuration (and make sure you know how to restore it). Restoring an earlier working configuration may be useful if the Switch becomes unstable or even crashes. If you forget your password, you will have to reset the Switch to its factory-default settings. If you backed up an earlier configuration file, you would not have to totally re-configure the Switch. You could simply restore your last configuration.

CHAPTER 2

Hardware Installation and Connection

2.1 Installation Scenarios

This chapter shows you how to install and connect the Switch.

See [Section 1.1 on page 9](#) for a comparison of hardware features for each model.

The Switch can be:

- Placed on a desktop.
- Mounted on a wall.
- Rack-mounted on a standard EIA rack.

See the following table for a comparison of the hardware installation methods of each Switch:

Table 4 Mounting Methods

MODEL FEATURE	GS1100-10HP (REVISION B1)	GS1100-10HP (REVISION A1)
Desktop Placement	Yes	Yes
Wall-mountable	Yes	Yes
Rack-mountable	No	No

Table 5 Mounting Methods

MODEL FEATURE	GS1100-16	GS1100-16E	GS1100-16EP	GS1100-24	GS1100-24E
Desktop Placement	Yes	Yes	Yes	No	Yes
Wall-mountable	Yes	Yes	Yes	No	Yes
Rack-mountable	Yes	No	No	Yes	Yes

2.2 Safety Precautions

Please observe the following before using the Switch:

- It is recommended to ask an authorized technician to attach the Switch on a desk or to the rack or wall. Use the proper screws to prevent damage to the Switch. See the **Installation Requirements** sections in this chapter to know the types of screws and screwdrivers for each mounting method.
- Make sure there is at least 2 cm of clearance on the top and bottom of the Switch, and at least 5 cm of clearance on all four sides of the Switch. This allows air circulation for cooling.

- Do NOT block the ventilation holes nor store cables or power cords on the Switch. Allow clearance for the ventilation holes to prevent your Switch from overheating. This is especially crucial when your Switch does not have fans. Overheating could affect the performance of your Switch, or even damage it.
- The surface of the Switch could be hot when it is functioning. Do NOT put your hands on it. You may get burned. This could happen especially when you are using a fanless Switch.
- The Switches with fans are not suitable for use in locations where children are likely to be present.

To start using the Switch, simply connect the power cables to turn it on.

2.3 Desktop Placement Procedure

- 1 Make sure the Switch is clean and dry.
- 2 Remove the adhesive backing from the rubber feet.
- 3 Attach the rubber feet to each corner on the bottom of the Switch. These rubber feet help protect the Switch from shock or vibration and ensure space between devices when stacking.

Figure 4 Attaching Rubber Feet

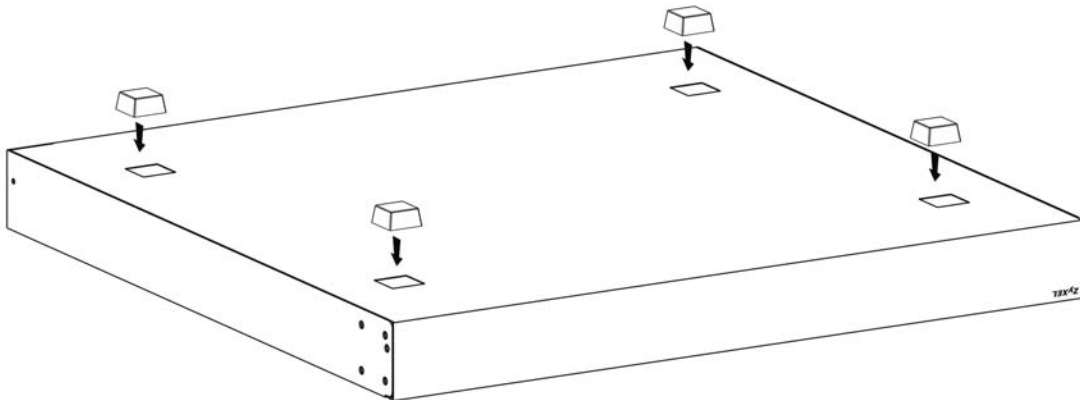

- 4 Set the Switch on a smooth, level surface strong enough to support the weight of the Switch and the connected cables. Make sure there is a power outlet nearby.

Cautions:

- Avoid stacking fanless Switches to prevent overheating.
- Ensure enough clearance around the Switch to allow air circulation for cooling.
- Do NOT remove the rubber feet as it provides space for air circulation.

2.4 Wall Mounting

The Switch can be mounted on a wall (see [Table 4 on page 14](#)). You may need screw anchors if mounting on a concrete or brick wall.

Do the following to mount your Switch on a wall.

See the following table for the recommended spacing between screws.

Unmanaged (UM) Switch

Table 6 Distance between the holes for wall mounting

MODEL	DISTANCE
GS1100-10HP (Revision B1)	176 mm
GS1100-10HP (Revision A1)	176 mm
GS1100-16	148 mm
GS1100-24E	120 mm

Unmanaged Plus (UM+) Switch

Table 7 Distance between the holes for wall mounting

MODEL	DISTANCE
GS1100-16	110 mm
GS1100-16E GS1100-16EP	160 mm
GS1100-24E	112 mm

2.4.1 Installation Requirements

- Distance above the floor: At least 1.8 m (5.9 feet)
- Two M4 screws and a #2 Philips screwdriver
- Two screw anchors (optional)

Figure 5 GS1100-10HP(Revision A1) / GS1100-10HP (Revision B1) Screw Specs

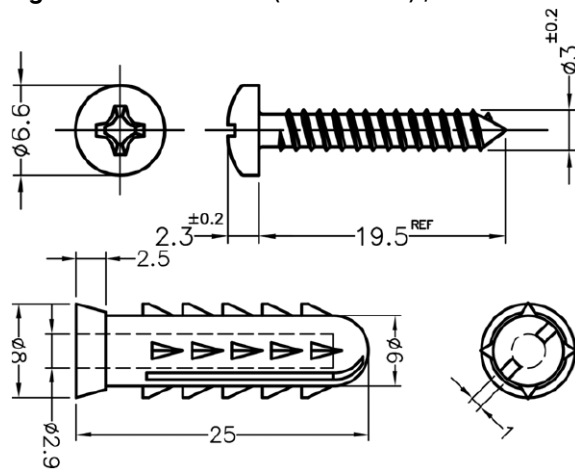
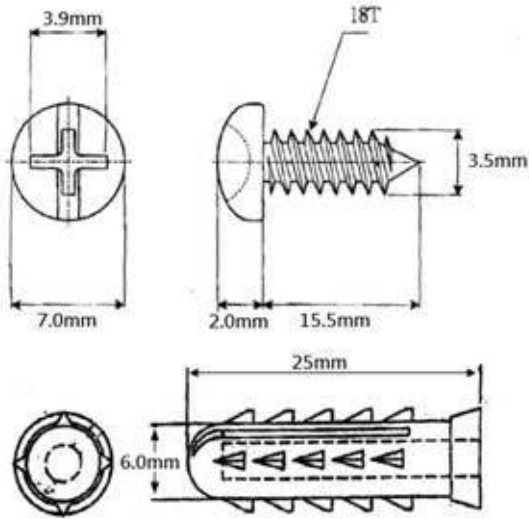

Figure 6 GS1100-16 / GS1100-16E / GS1100-16EP / GS1100-24E Screw Specs



- 1 Select a position free of obstructions on a wall strong enough to hold the weight of the Switch.
- 2 Mark two holes on the wall at the appropriate distance apart for the screws.

WARNING! Be careful to avoid damaging pipes or cables located inside the wall when drilling holes for the screws.

- 3 If using screw anchors, drill two holes for the screw anchors into the wall. Push the anchors into the full depth of the holes, then insert the screws into the anchors.

If not using screw anchors, use a screwdriver to insert the screws into the wall.

WARNING! Be careful to insert the screws into the anchors or the wall. Do NOT insert the screws all the way in - leave a small gap of about 1.0~1.2 mm. A gap greater than 1.2 mm may result in equipment malfunction during wall mounting!

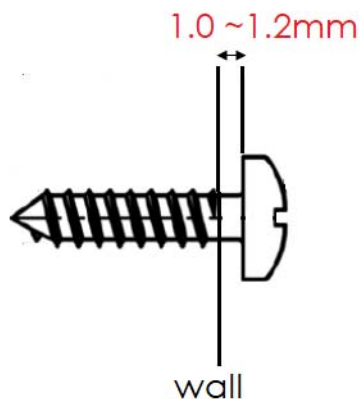

- 4 Make sure the screws are fastened well enough to hold the weight of the Switch with the connection cables.

- 5 Align the holes on the back of the Switch with the screws on the wall. Hang the Switch on the screws.

Note: Make sure there is enough clearance between the wall and the Switch to allow ventilation.

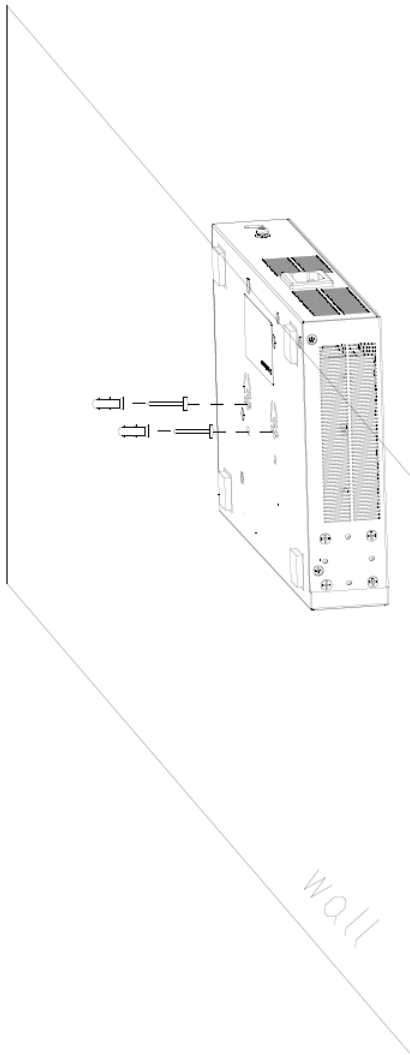

WARNING! The Switch should be wall-mounted horizontally, and make sure the front panel is facing down. The Switch's side panels with ventilation slots should not be facing up or down as this position is less safe.

2.5 Mounting the Switch on a Rack

The Switch can be mounted on an EIA standard size, 19-inch rack or in a wiring closet with other equipment (see [Table 4 on page 14](#)). Follow the steps below to mount your Switch on a standard EIA rack using a rack-mounting kit.

Note: Make sure there is enough clearance between each equipment on the rack for air circulation.

2.5.1 Installation Requirements

- Two mounting brackets.
- Eight M3 flat head screws and a #2 Philips screwdriver.
- Four M5 flat head screws and a #2 Philips screwdriver.

2.5.2 Precautions

- Make sure the rack will safely support the combined weight of all the equipment it contains. The maximum weight a bracket can hold is 21.5 kg.
- Make sure the position of the Switch does not make the rack unstable or top-heavy. Take all necessary precautions to anchor the rack securely before installing the unit.

2.5.3 Attaching the Mounting Brackets to the Switch

- 1 Position a mounting bracket on one side of the Switch, lining up the four screw holes on the bracket with the screw holes on the side of the Switch.

Figure 7 Attaching the Mounting Brackets (GS1100-16 and GS1100-24E)

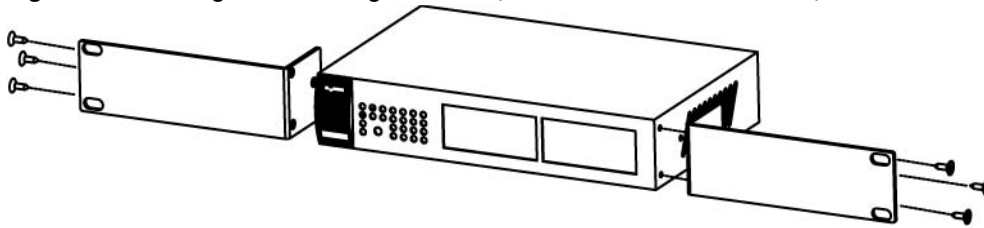
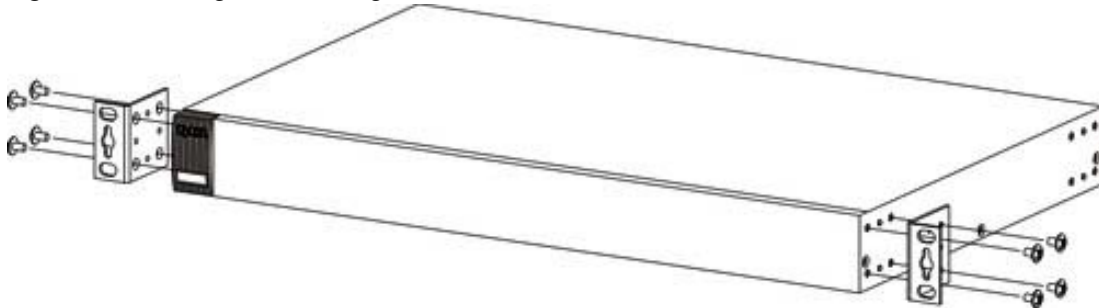

Figure 8 Attaching the Mounting Brackets (GS1100-24)



- 2 Using a #2 Philips screwdriver, install the M3 flat head screws through the mounting bracket holes into the Switch.
- 3 Repeat steps 1 and 2 to install the second mounting bracket on the other side of the Switch.
- 4 You may now mount the Switch on a rack. Proceed to the next section.

2.5.4 Mounting the Switch on a Rack

- 1 Position a mounting bracket (that is already attached to the Switch) on one side of the rack, lining up the two screw holes on the bracket with the screw holes on the side of the rack.

Figure 9 Mounting the Switch on a Rack (GS1100-16 and GS1100-24E)

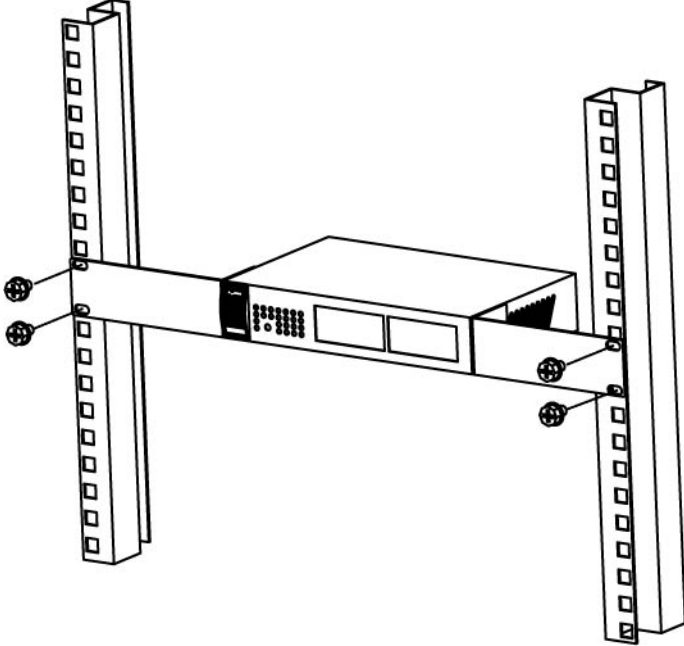
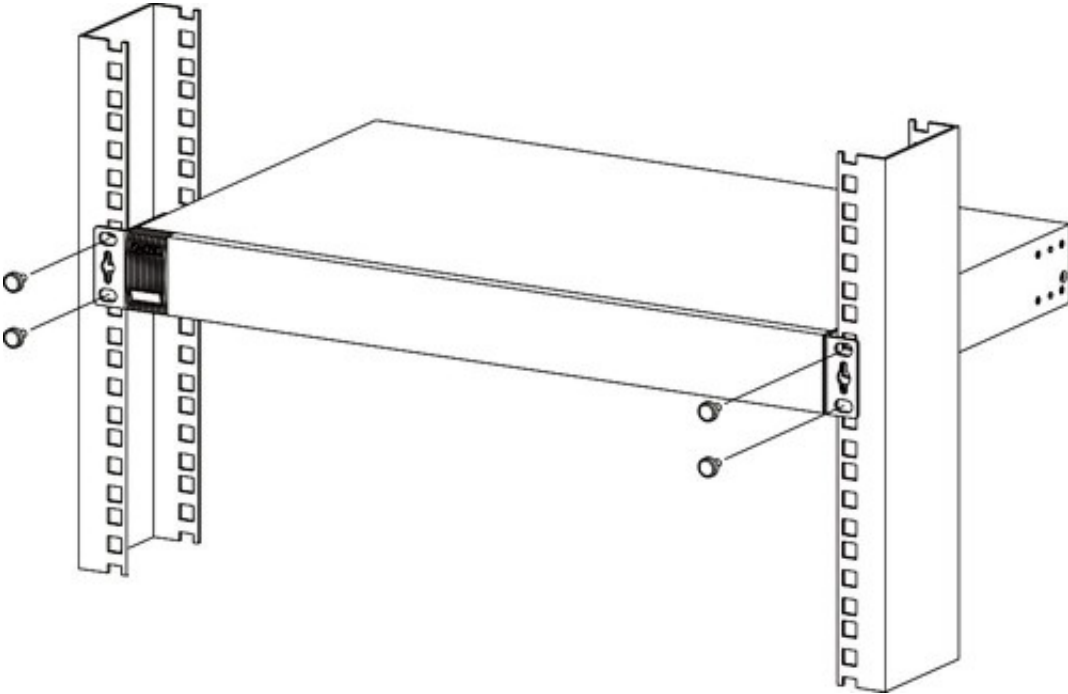

Figure 10 Mounting the Switch on a Rack (GS1100-24)



- 2 Using a #2 Philips screwdriver, install the M5 flat head screws through the mounting bracket holes into the rack.

Note: Make sure you tighten all the four screws to prevent the Switch from getting slanted.

- 3 Repeat steps 1 and 2 to attach the second mounting bracket on the other side of the rack.

CHAPTER 3

Hardware Panels

This chapter describes the front panel and rear panel of the Switch and shows you how to make the hardware connections.

3.1 Front Panel

You can use either crossover or straight-through cables for all the ports.

Refer to [Section 1.1 on page 9](#) for more information on feature differences between models.

The following figures show the front panels of the Switch.

Unmanaged (UM) Switch

Figure 11 GS1100-10HP (Revision B1)



Figure 12 GS1100-10HP (Revision A1)



Figure 13 GS1100-16 REVISION B1 (PART No.: GS1100-16-EU0103F, GS1100-16-US0103F)



Figure 14 GS1100-24E REVISION B1 (PART No.: GS1100-24E-EU0103F, GS1100-24E-US0103F)



Figure 15 GS1100-24 REVISION B1 (PART No.: GS1100-24-EU0103F, GS1100-24-US0103F)



Unmanaged Plus (UM+) Switch

Figure 16 GS1100-16

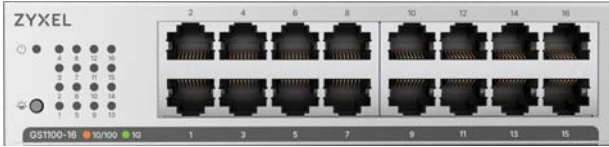

Figure 17 GS1100-16E



Figure 18 GS1100-16EP



Figure 19 GS1100-24E



You can use unshielded twisted pair (UTP) or shielded twisted-pair (STP) Ethernet cables for RJ-45 ports. The following table describes the types of network cable used for the different connection speeds.

Table 8 Network Cable Types

SPEED	NETWORK CABLE TYPE
10 Mbps	Category 3, 4 or 5 UTP/STP
100 Mbps	Category 5 UTP/STP
1000 Mbps	Category 5e, 6 UTP/STP

3.1.1 LED OFF Button

Turn off all the LEDs except for power. You may do this if the Switch is in a public place and you want to keep the Switch inconspicuous, and unobtrusive.

3.1.2 IEEE 802.3az EEE Button

Refer to [Section 1.1 on page 9](#) for more information on feature differences between models.

The Switch supports the IEEE 802.3az EEE (Energy Efficient Ethernet) standard to help reduce power consumption. This allows the Switch to go into power saving mode and switch off part of receive and transmit circuitry when it is not transmitting or receiving data through an Ethernet connection.

An EEE-enabled device initiates Low Power Idle (LPI) signals to negotiate and wake up the remote device when there is data to be transmitted. To use EEE, both devices should be EEE compliant.

EEE is configured on a per-system basis in the Switch. If one of the networking devices that connect to the Switch does not support EEE, EEE may not work in the Switch to save power.

Press the **IEEE 802.3az ON/OFF** to turn on the EEE feature. Disable it if you do not want the network performance to be impacted due to the latency from the additional time required for the sleep and wake transition or if the remote side does not support it.

3.1.3 Gigabit Ethernet Ports

The Switch has 1000Base-T auto-negotiating, auto-crossover Ethernet ports. In 10/100/1000 Mbps Gigabit, the speed can be 10 Mbps, 100 Mbps or 1000 Mbps and the duplex mode can be half duplex or full duplex.

The 10 Base-T/100 Base-TX/1000 Base-T RJ-45 ports are auto-negotiating and auto-crossover.

An auto-negotiating port can detect and adjust to the optimum Ethernet speed (10/100/1000 Mbps) and duplex mode (full duplex) of the connected device.

An auto-crossover (auto-MDI/MDI-X) port automatically works with a straight-through or crossover Ethernet cable.

When auto-negotiation is turned on, an Ethernet port negotiates with the peer automatically to determine the connection speed and duplex mode. If the peer Ethernet port does not support auto-negotiation or turns off this feature, the Switch determines the connection speed by detecting the signal on the cable. When the Switch's auto-negotiation is turned off, an Ethernet port uses the pre-configured speed and duplex mode when making a connection. Make sure that the settings of the peer Ethernet port are the same in order to connect.

3.1.3.1 Auto-crossover

All ports support auto-crossover, that is auto-MDIX ports (Media Dependent Interface Crossover), so you may use either a straight-through Ethernet cable or crossover Ethernet cable for all Gigabit port connections. Auto-crossover ports automatically sense whether they need to function as crossover or straight ports, so crossover cables can connect both computers and switches or hubs.

3.1.4 PoE

The Switch supports the IEEE 802.3af Power over Ethernet (PoE), IEEE 802.3at Power over Ethernet plus (PoE+). The Switch is a Power Sourcing Equipment (PSE) because it provides a source of power through its Ethernet ports. Each device that receives power through an Ethernet port is a powered device (PD).

The Switch can adjust the power supplied to each PD according to the PoE standard the PD supports. PoE standards are:

- IEEE 802.3af Power over Ethernet (PoE)
- IEEE 802.3at Power over Ethernet (PoE+)

The following table describes the PoE features of the Switch by PoE standard.

Table 9 PoE Standards

POE FEATURES	POE	POE+
IEEE Standard	IEEE 802.3af	IEEE 802.3at
PoE Type	Type 1	Type 2

Table 9 PoE Standards (continued)

POE FEATURES	POE	POE+
IEEE Power Classification and Maximum Power Per Port	Class 0: 15.4 W Class 1: 4 W Class 2: 7 W Class 3: 15.4 W	Class 4: 30 W
Port Voltage Range	44 – 57 V	50 – 57 V
Supported Cables	Cat3 or better	Cat5 or better
Twisted Pairs Cables	2-pair	2-pair

3.1.5 Restore Button

Refer to [Section 1.1 on page 9](#) for more information on hardware differences between models.

To set the Switch back to the factory default settings, press the restore button for more than 3 seconds until the **PWR** LED begins to blink and then release it. When the **PWR** LED begins to blink, the defaults have been restored and the Switch restarts.

3.1.6 SFP Slots

Refer to [Section 1.1 on page 9](#) for more information on hardware differences between models.

These are slots for SFP (Small Form-Factor Pluggable) modules, such as SFP transceivers. A transceiver is a single unit that houses a transmitter and a receiver. Use a transceiver to connect a fiber optic cable to the Switch. The Switch does not come with transceivers. You must use transceivers that comply with the Small Form-factor Pluggable (SFP) Transceiver MultiSource Agreement (MSA). See the SFF committee's INF-8074i specification Rev 1.0 for details.

You can change transceivers while the Switch is operating. You can use different transceivers to connect to Ethernet switches with different types of fiber or even copper cable connectors.

- Type: SFP connection interface
- Connection speed: 100/1000 Mbps

WARNING! To avoid possible eye injury, do not look into an operating fiber optic module's connectors.

HANDLING! All transceivers are static sensitive. To prevent damage from electrostatic discharge (ESD), it is recommended you attach an ESD preventive wrist strap to your wrist and to a bare metal surface when you install or remove a transceiver.

STORAGE! All modules are dust sensitive. When not in use, always keep the dust plug on. Avoid getting dust and other contaminant into the optical bores, as the optics do not work correctly when obstructed with dust.

3.1.6.1 Transceiver Installation

Use the following steps to install a transceiver.

- 1 Attach an ESD preventive wrist strap to your wrist and to a bare metal surface.
- 2 Align the transceiver in front of the slot opening.
- 3 Make sure the latch is in the lock position (latch styles vary), then insert the transceiver into the slot with the exposed section of PCB board facing down.
- 4 Press the transceiver firmly until it clicks into place.
- 5 The Switch automatically detects the installed transceiver. Check the LEDs to verify that it is functioning properly.
- 6 Remove the dust plugs from the transceiver and cables (dust plug styles vary).
- 7 Identify the signal transmission direction of the fiber optic cables and the transceiver. Insert the fiber optic cable into the transceiver.

Figure 20 Latch in the Lock Position

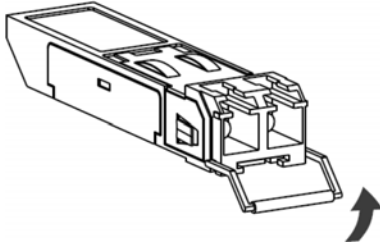

Figure 21 Transceiver Installation Example

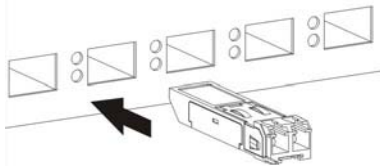
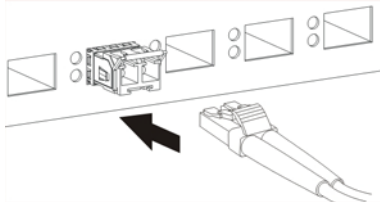

Figure 22 Connecting the Fiber Cables



3.1.6.2 Transceiver Removal

Use the following steps to remove an SFP transceiver.

- 1 Attach an ESD preventive wrist strap to your wrist and to a bare metal surface on the chassis.
- 2 Remove the fiber optic cables from the transceiver.
- 3 Pull out the latch and down to unlock the transceiver (latch styles vary).

Note: Make sure the transceiver's latch is pushed all the way down, so the transceiver can be pulled out successfully.

- 4 Pull the latch, or use your thumb and index finger to grasp the tabs on both sides of the transceiver, and carefully slide it out of the slot.

Note: Do NOT pull the transceiver out by force. You could damage it. If the transceiver will not slide out, grasp the tabs on both sides of the transceiver with a slight up or down motion and carefully slide it out of the slot. If unsuccessful, contact Zyxel Support to prevent damage to your Switch and transceiver.

- 5 Insert the dust plug into the ports on the transceiver and the cables.

Figure 23 Removing the Fiber Optic Cables

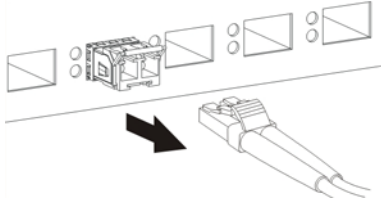

Figure 24 Opening the Transceiver's Latch Example

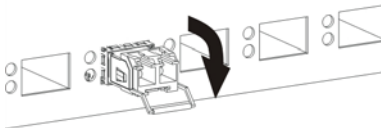
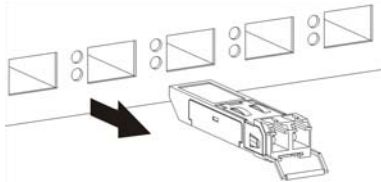

Figure 25 Transceiver Removal Example



3.2 Rear Panel

The following figures show the rear panels of the Switch. The power receptacle is located on the rear panel of the Switch. Refer to the power supply requirements on the panel.

Unmanaged (UM) Switch

Figure 26 GS1100-10HP (Revision B1)



Figure 27 GS1100-10HP (Revision A1)



Figure 28 GS1100-16 REVISION B1 (PART No.: GS1100-16-EU0103F, GS1100-16-US0103F)**Figure 29** GS1100-24 REVISION B1 (PART No.: GS1100-24-EU0103F, GS1100-24-US0103F)**Figure 30** GS1100-24E REVISION B1 (PART No.: GS1100-24E-EU0103F, GS1100-24E-US0103F)

Unmanaged Plus (UM+) Switch

Figure 31 GS1100-16**Figure 32** GS1100-16E**Figure 33** GS1100-16EP**Figure 34** GS1100-24E

3.2.1 Grounding

Refer to [Section 1.1 on page 9](#) for more information on hardware differences between models.

Grounding is a safety measure to direct excess electric charge to the ground. It prevents damage to the Switch, and protects you from electrocution. Use the grounding screw on the rear panel and the ground wire of the AC power supply to ground the Switch.

The grounding terminal and AC power ground where you install the Switch must follow your country's regulations. Qualified service personnel must ensure the building's protective earthing terminals are valid terminals.

Installation of Ethernet cables must be separate from AC power lines. To avoid electric surge and electromagnetic interference, use a different electrical conduit or raceway (tube/trough or enclosed conduit for protecting electric wiring) that is 15 cm apart, or as specified by your country's electrical regulations.

Any device that is located outdoors and connected to this product must be properly grounded and surge protected. To the extent permissible by your country's applicable law, failure to follow these guidelines could result in damage to your Switch which may not be covered by its warranty.

Note: The specification for surge or ESD protection assumes that the Switch is properly grounded.

- 1 Remove the M4 ground screw from the Switch's rear panel.
- 2 Secure a green or yellow ground cable (16 AWG or smaller) to the Switch's rear panel using the M4 ground screw.

Figure 35 Grounding

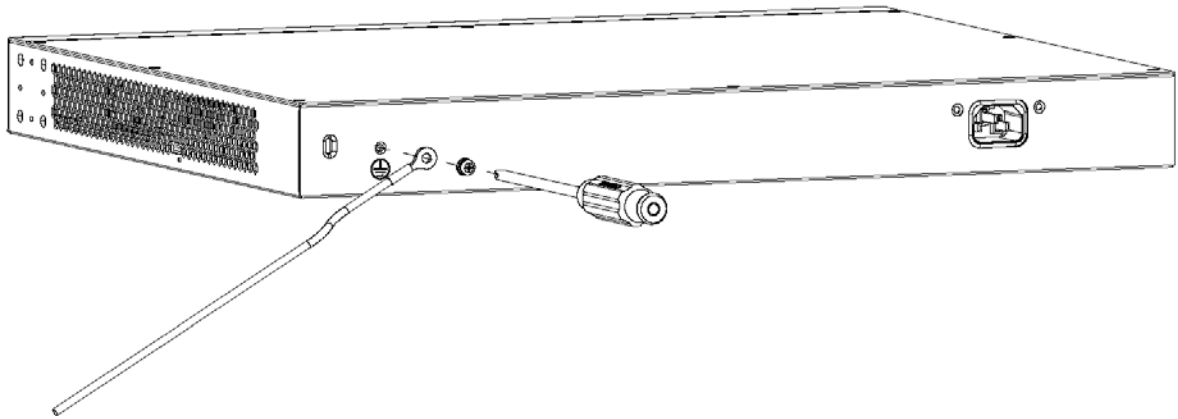

- 3 Attach the other end of the ground cable to a grounding bar located on the rack where you install the Switch or to an on-site grounding terminal.

Figure 36 Attach Ground Cable to Grounding Bar or On-site Grounding Terminal

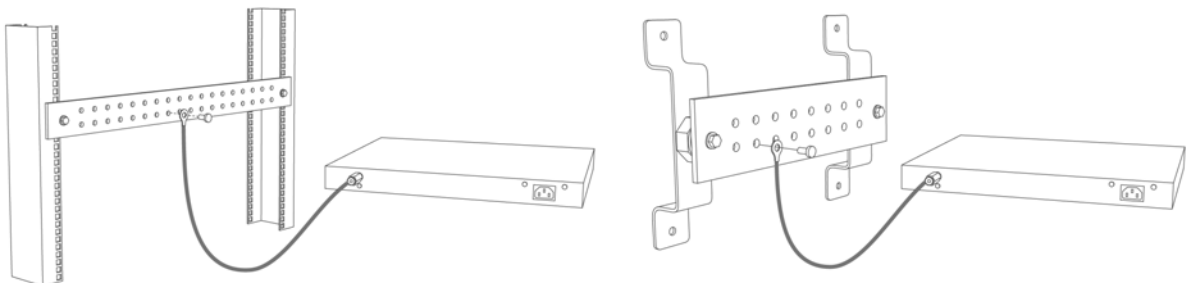

- 4 The grounding terminal of the server rack or on-site grounding terminal must also be grounded and connected to the building's main grounding electrode. Make sure the grounding terminal is connected to the buildings grounding electrode and has an earth resistance of less than 10 ohms, or according to your country's electrical regulations.

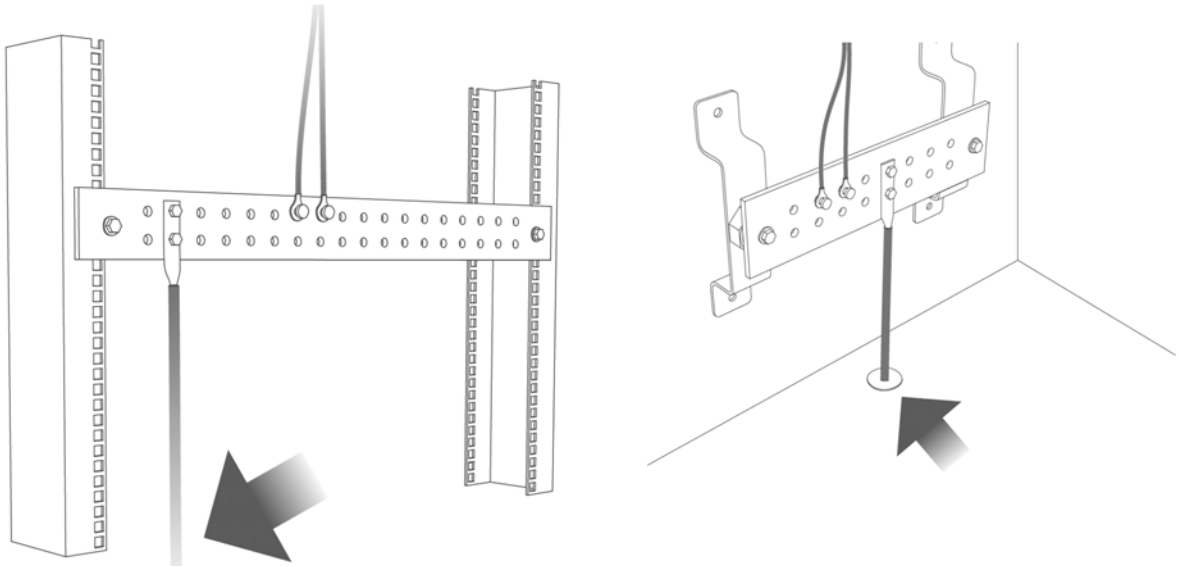
Figure 37 Connecting to the Building's Main Grounding Electrode

If you are uncertain that suitable grounding is available, contact the appropriate electrical inspection authority or an electrician.

This Switch must be grounded. Do this before you make other connections.

3.2.2 Power Connection

Note: Make sure you are using the correct power source as shown on the panel.

Models with Power Adapter: Connect the supplied power adapter to the power receptacle on the rear panel. Then use the included power cord to connect the power adapter to an appropriate power source. Set the power switch to the **ON** position (for GS1100-10HP Revision A1 only).

Models with Power Cord: To connect power to the Switch, insert the female end of the supplied power cord to the AC power receptacle on the rear panel. Connect the other end of the power cord to an appropriate power outlet.

3.2.3 Kensington Lock (for UM+ model)

The Kensington lock (K-lock) slot, identified by the  icon, is used to protect the Switch from theft. Insert the lock head of a Kensington security cable into the K-lock slot and secure the cable around a fixed object, such as a desk or table leg.

Warning (for GS1100-16EP)	For safety and fire protection, keep the Kensington lock protective cover attached to the K-lock slot whenever a security cable is not connected.
------------------------------	---

3.3 LEDs

The LED Indicators give real-time information about the status of the Switch. After you connect the power to the Switch, view the LEDs to ensure proper functioning of the Switch and as an aid in troubleshooting. The following table provides descriptions of the LEDs.

The following table describes the LEDs.

Table 10 LED Descriptions: GS1100-10HP (Revision B1)

LED	COLOR	STATUS	DESCRIPTION
PWR	Green	On	The Switch is receiving power from the power module in the power slot.
		Off	The Switch is not receiving power from the power module in the power slot.
PoE MAX	Amber	On	Power supplied to the PoE port(s) has reached ninety-five percent of the power budget limit or has exceeded the total PoE power budget on the Switch.
		Off	Power supplied to the PoE port(s) is below the power budget limit.
PoE 10/100/1000Base-T Ports			
Link/ACT (Left)	Green	On	The link to a 1 Gbps Ethernet network is up.
		Blinking	The Switch is transmitting or receiving to/from at 100 /1000 Mbps Ethernet network.
		Off	The port is not connected to an Ethernet network.
PoE Mode (Right)	Green	On	Power supplied to all PoE Ethernet ports meets the IEEE 802.3at standard
		Off	There is no power supplied.
SFP	Green	On	The uplink port is linking at 100 / 1000 Mbps.
		Blinking	The port is receiving or transmitting data at 100 / 1000 Mbps.
		Off	There is no link or port, or the uplink port is off.

Table 11 LED Descriptions: GS1100-10HP (Revision A1)

LED	COLOR	STATUS	DESCRIPTION
PWR	Green	On	The Switch is receiving power from the power module in the power slot.
		Off	The Switch is not receiving power from the power module in the power slot.
PoE MAX	Amber	On	Power supplied to the PoE port(s) has reached ninety-five percent of the power budget limit or has exceeded the total PoE power budget on the Switch.
		Off	Power supplied to the PoE port(s) is below the power budget limit.
PoE 10/100/1000Base-T Ports			
Link/ACT (Left)	Green	On	The link to a 1 Gbps Ethernet network is up.
		Blinking	The Switch is transmitting or receiving to/from a1 Gbps Ethernet network.
		Off	The port is not connected to an Ethernet network.
	Amber	On	The link to a 10 Mbps or a 100 Mbps Ethernet network is up.
		Blinking	The Switch is transmitting or receiving to/from a 10 Mbps or a 100 Mbps Ethernet network.
		Off	The link to an Ethernet network is down.
PoE Mode (Right)	Green	On	Power supplied to all PoE Ethernet ports meets the IEEE 802.3at standard.
		Off	There is no power supplied.
	Amber	On	Power supplied to all PoE Ethernet ports meets the IEEE 802.3af standard.
		Off	There is no power supplied.

Table 11 LED Descriptions: GS1100-10HP (Revision A1) (continued)

LED	COLOR	STATUS	DESCRIPTION
SFP	Green	On	The uplink port is linking at 1000 Mbps.
		Blinking	The port is receiving or transmitting data at 1000 Mbps.
		Off	There is no link or port, or the uplink port is down.
	Amber	On	The uplink port is linking at 100 Mbps.
		Blinking	The port is receiving or transmitting data at 100 Mbps.
		Off	There is no link or port, or the uplink port is down.

Table 12 LED Descriptions: GS1100-16 (UM) / 24 / 24E (UM)

LED	COLOR	STATUS	DESCRIPTION
PWR	Green	On	The Switch is receiving power from the power module in the power slot.
		Off	The Switch is not receiving power from the power module in the power slot.
LINK/ACT	Green	On	The link to a 1000 Mbps Ethernet network is up.
		Blinking	The Switch is transmitting/receiving to/from a 1000 Mbps Ethernet network.
	Amber	On	The link to a 10 Mbps or a 100 Mbps Ethernet network is up.
		Blinking	The Switch is transmitting/receiving to/from a 10 Mbps or a 100 Mbps Ethernet network.
		Off	The port is not connected to an Ethernet network or the Switch is off.
Uplink Port LED (SFP)	Green	On	The port is connected to an Ethernet network at 1000 Mbps.
		Blinking	The port is receiving or transmitting data at 1000 Mbps.
	Amber	On	The link to a 100 Mbps Ethernet network is up.
		Blinking	The port is receiving or transmitting data at 100 Mbps.
		Off	The port is not connected to an Ethernet network or the Switch is off.

Table 13 LED Descriptions: GS1100-16 (UM+) / 16E / 24E (UM+)

LED	COLOR	STATUS	DESCRIPTION
PWR	Green	On	The Switch is receiving power from the power module in the power slot.
		Off	The Switch is not receiving power from the power module in the power slot.
LINK/ACT	Green (1000 Mbps)	On	The port has a successful 10/100 Mbps or 1000 Mbps connection.
		Fast Blinking	The Switch is receiving or transmitting data through the port.
	Yellow (10/100Mbps)	Slow Blinking (once per second)	The Switch detects a loop on the port. See Loop Status for details.
		Off	The port is not connected to an Ethernet network or the Switch is off.

Table 14 LED Descriptions: GS1100-16EP

LED	COLOR	STATUS	DESCRIPTION
PWR	Green	On	The Switch is receiving power from the power module in the power slot.
		Off	The Switch is not receiving power from the power module in the power slot.

Table 14 LED Descriptions: GS1100-16EP (continued)

LED	COLOR	STATUS	DESCRIPTION
LINK/ACT (Left)	Green (1000 Mbps)	On	The port has a successful 10/100 Mbps or 1000 Mbps connection.
		Fast Blinking	The Switch is receiving or transmitting data through the port.
	Yellow (10/ 100Mbps)	Slow Blinking (once per second)	The Switch detects a loop on the port. See Loop Status for details.
		Off	The port is not connected to an Ethernet network or the Switch is off.
PoE Mode (Right)	Green	On	The Switch is supplying power through the port.
		Blinking	An external PD fault is detected. The Switch fails to supply power through the port.
		Off	No power is being supplied through the port.
PoE Max	Yellow	On	PoE power usage exceeds 95% of the total power supply budget.
		Off	PoE power usage is less than 95% of the total power supply budget.

CHAPTER 4

Web Configurator

4.1 Overview

This section introduces the configuration and functions of the Web Configurator.

The Web Configurator is an HTML-based management interface that allows easy system setup and management through a web browser. Use a web browser that supports HTML5, such as Microsoft Edge, Mozilla Firefox, or Google Chrome. The recommended minimum screen resolution is 1024 by 768 pixels.

4.2 Access the Switch

The Switch may have a dynamic (default) or static IP address.

Dynamic IP Address

By default, the Switch operates as a DHCP client and automatically obtains an IP address when connected to a network with an active DHCP server. The graphic below shows an example.

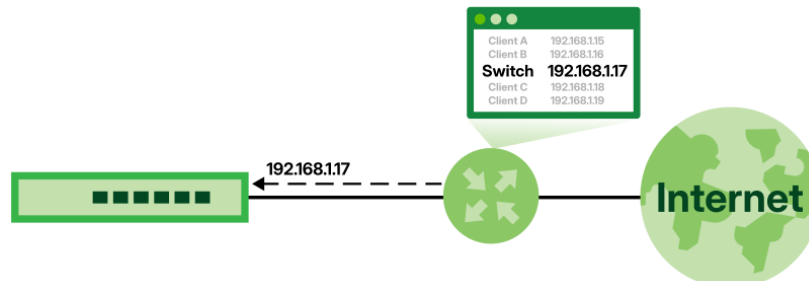

- 1 Log in to the router and check its DHCP clients list to find the IP address assigned to the Switch.
- 2 Open your web browser and enter the IP address of the Switch in the address bar to access the Web Configurator.

Static IP Address

If the Switch does not receive a dynamic IP address, the Switch will assign itself a management IP address of 192.168.1.3/24. In this case, you can access the Switch and change the management IP address to a static IP address that is in the network where the Switch will be deployed.

- 1 Make sure your Switch is not connected to a network.

- 2 Set your computer's IP address manually to one that is in the same subnet as the Switch's static IP address. The Switch's default IP address is 192.168.1.3, you can assign your computer any IP address from 192.168.1.4 to 192.168.1.254.
- 3 Open your web browser and enter the 192.168.1.3 in the address bar to access the Web Configurator.
- 4 Go to the **Management** screen and set the Switch's IP address to an available static IP address that is in the network where the Switch will be deployed. See [IP Address](#).

Note: Make sure you can use the static IP address. Do not randomly assign one.

- 5 Your computer will be disconnected from the Switch once the static IP address is applied. Change your computer's network settings to use a DHCP-assigned IP address and connect it to the network where you will deploy the Switch.
- 6 On your computer, open a web browser and enter the IP address of the Switch that you configured above.

4.3 Log in to the Web Configurator

Log in to the Web Configurator after accessing the Switch.

- 1 The **Log in** screen appears. Enter the default password located on the back label of the Switch.

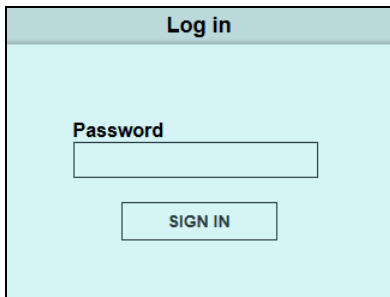

- 2 The following screen displays if you log into the Switch for the first time. Enter a new password. Password length has to be between 9 and 64 characters. Allowed characters include lowercase letters (a-z), uppercase letters (A-Z), numbers (0-9), and special characters such as ~ ! @ # \$ % ^ & * () _ + ` - = { } [] ; < > . / \. Spaces are not allowed. Retype it to confirm and click **Apply** to view the **System** screen.

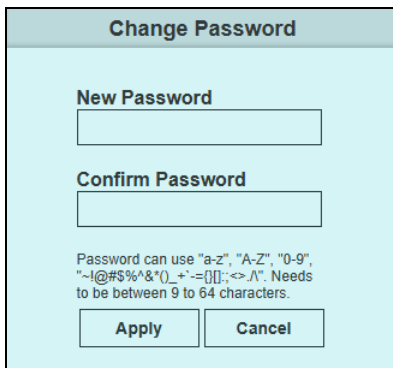

4.4 Web Configurator Layout

The **System** screen is the first screen that displays when you access the Web Configurator. The screens may vary slightly for different models.

The following figure shows the navigating components of a Web Configurator screen.

Figure 38 Web Configurator Layout

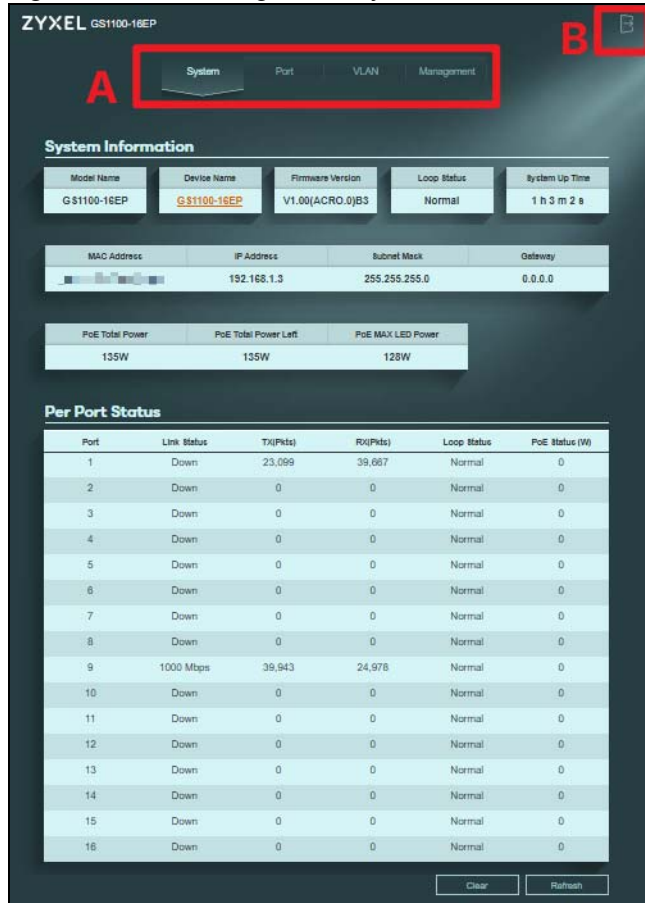

A – Click the menu items to open the screen in the main window.

B – Click this link to log out of the Web Configurator.

The following table describes the links in the navigation panel.

Table 15 Navigation Panel Links

LINK	DESCRIPTION
System	This link takes you to a screen that displays general system information, PoE status, and individual port statistics.
Port	This link takes you to a screen to enable loop detection and loop prevention. You can also configure the transmission speed, flow control, port isolation, and PoE on a port.

Table 15 Navigation Panel Links (continued)

LINK	DESCRIPTION
VLAN	This link takes you to a screen where you can set the PVID (Port VLAN ID) on a port and create/modify/delete IEEE 802.1Q VLAN for the Switch.
Management	This link takes you to screens where you can change the system login password, perform firmware upgrade and configuration file maintenance as well as reset/reboot the system. You can also configure the IP address and subnet mask, and enable IEEE 802.3az EEE and LED ECO Mode.

4.5 Switch Lockout / Resetting the Switch

You could block yourself (and all others) from managing the Switch if you do one of the following:

- Remove all ports from VLAN1 and you do not configure other VLAN groups.
- Forget the password and/or IP address.
- You forgot to log out of the Switch from a computer before logging in again on another computer.

Note: Be careful not to lock yourself and others out of the Switch.

If you forget the administrator password or cannot access the Web Configurator, you will need to use the **Restore** button of the Switch to reset it back to the factory defaults. See [Section 3.1.5 on page 24](#) for details.

This means that you will lose all configurations that you had previously and the password will be reset to the default unique password located on the Switch's back label. The IP address will also be reset to 192.168.1.3.

4.6 Logging Out of the Web Configurator

Click the logout icon in a screen to exit the Web Configurator. You have to log in with your password again after you log out. This is recommended after you finish a management session for security reasons.

Note: By default, you are automatically logged out of the Web Configurator after 5 minutes of inactivity. You can change this setting in **Management > HTTP Timeout**.

CHAPTER 5

Initial Setup Example

5.1 Overview

This chapter shows how to set up the Switch for use.

The following lists the configuration steps for the initial setup:

- [Change the IP Address](#)
- [Change the Password](#)

5.1.1 Change the IP Address

If you do not wish to set your Switch as a DHCP client (**DHCP client** field is **Disable**), assign an IP address for the Switch. The IP address makes it accessible from an outside network. It is used by the Switch to communicate with other devices in other networks.

In this example, you want to change the IP address to 192.168.1.5.

- 1 Click **Management** in the navigation panel.
- 2 Select **Disable** in the DHCP field.
- 3 Enter the new IP address **192.168.1.5** in the **IP Address** field. Click **Apply**.

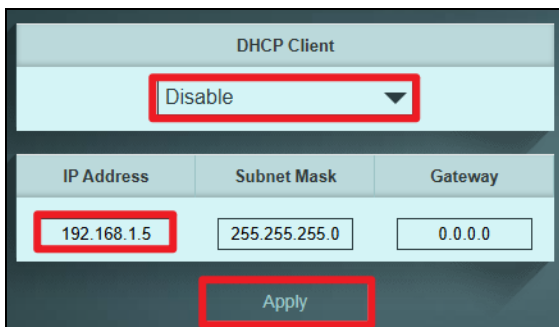

DHCP Client		
Disable		
IP Address	Subnet Mask	Gateway
192.168.1.5	255.255.255.0	0.0.0.0
Apply		

- 4 The following screen appears. Click **Confirm** to save the setting. Connection to the Web Configurator will be lost.

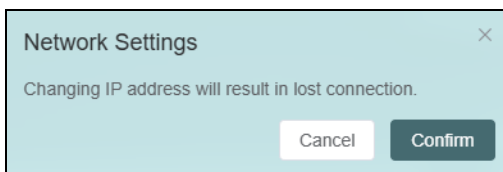

Network Settings

Changing IP address will result in lost connection.

Cancel Confirm

- 5 On your web browser, go to <http://192.168.1.5>.
- 6 A **Log in** screen appears. Enter the existing password and click **SIGN IN** to log in using the new IP address.

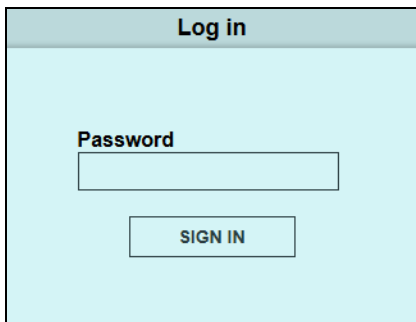

The screenshot shows a web browser window with a light blue background. At the top, there is a dark blue header with the text "Log in" in white. Below the header, the word "Password" is displayed in bold black text. Underneath "Password" is a white rectangular input field. Below the input field is a white rectangular button with the text "SIGN IN" in black, centered on the button.

5.1.2 Change the Password

The first time you log in to the Web Configurator, you will be asked to change the default password. If you wish to change the password again, perform the following steps:

- 1 Click **Management** in the navigation panel.
- 2 Under **Change Password**, enter your current password in the **Old Password** field.
- 3 Enter the new system password in the **New Password** field. Password length has to be between 9 and 64 characters. Allowed characters include lowercase letters (a-z), uppercase letters (A-Z), numbers (0-9), and special characters such as ~ ! @ # \$ % ^ & * () _ + ` - = { } [] ; < > . \. Spaces are not allowed.
- 4 Enter the new password again to in the **Confirm Password** field for confirmation.
- 5 Click **Apply**. You will automatically be logged out of the Web Configurator.
- 6 A **Log in** screen appears. Enter the new password and click **SIGN IN** to log in using the new password.

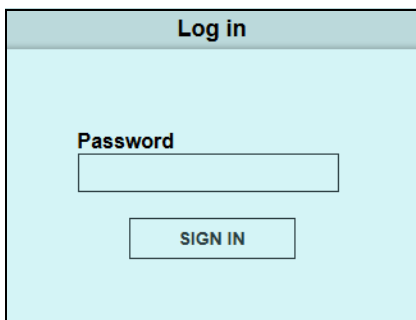

The screenshot shows a web browser window with a light blue background. At the top, there is a dark blue header with the text "Log in" in white. Below the header, the word "Password" is displayed in bold black text. Underneath "Password" is a white rectangular input field. Below the input field is a white rectangular button with the text "SIGN IN" in black, centered on the button.

CHAPTER 6

Tutorials

6.1 Overview

This chapter shows you how to set up the Switch's various features.

- [Creating a VLAN and Setting Port VID](#)
- [Upgrade Firmware on the Switch](#)
- [Back up a Configuration File](#)
- [Restore Configuration](#)
- [Power over Ethernet \(PoE\) Configuration](#)

6.2 Creating a VLAN and Setting Port VID

By default, all ports on the Switch are in VLAN 1.

VLANs confine broadcast frames to the VLAN group in which the ports belongs. You can create a VLAN group with fixed port members to do this.

6.2.1 Creating a VLAN

If you want to have a port (for example port 1 (**P1**)) belong to another VLAN as well, say **VLAN 2**, you need to create a VLAN first, and then add the port to the VLAN.

Figure 39 Initial Setup Network Example: VLAN

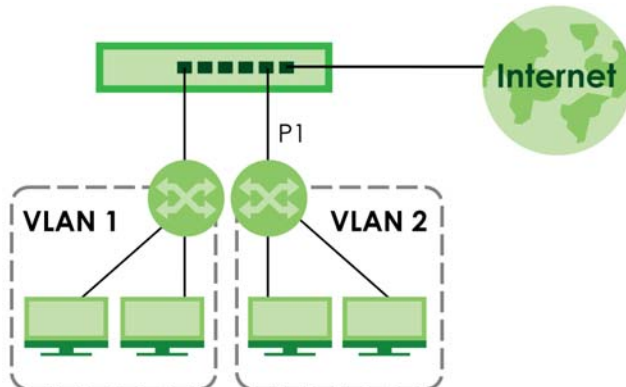

- 1 Click **VLAN** in the navigation panel and click the **Create New VLAN** button.

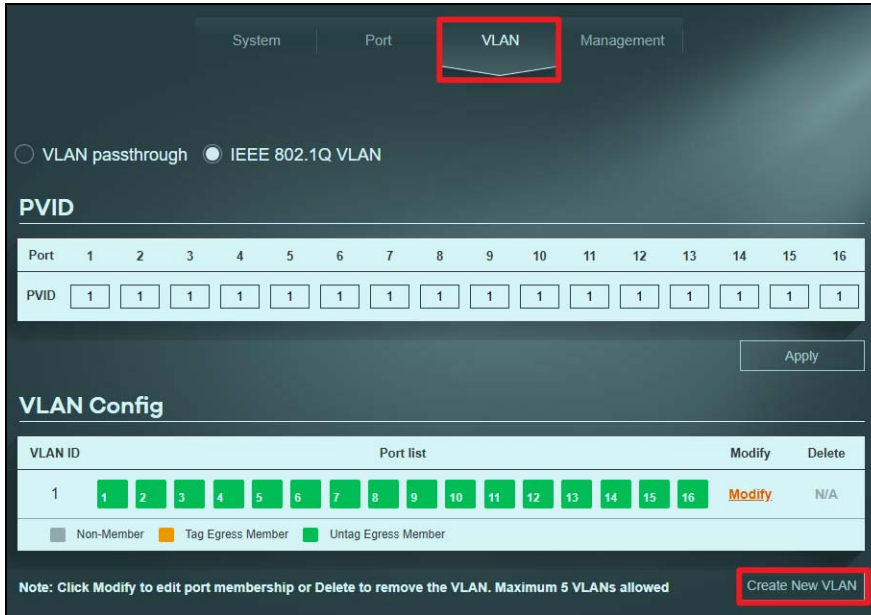

- 2 Enter 2 in the **VLAN ID** field for the VLAN2 network.
- 3 Since the VLAN2 network is connected to port 1 on the Switch, configure port 1 to be a permanent member of the VLAN. To ensure that VLAN-unaware devices (such as computers and hubs) can receive frames properly, click the port's box color to green to set the Switch to remove VLAN tags before sending. Clicking the port's checkbox loops between untagging, non-member, and tagging.
- 4 Change the box color of other ports not a member of the VLAN group to gray.

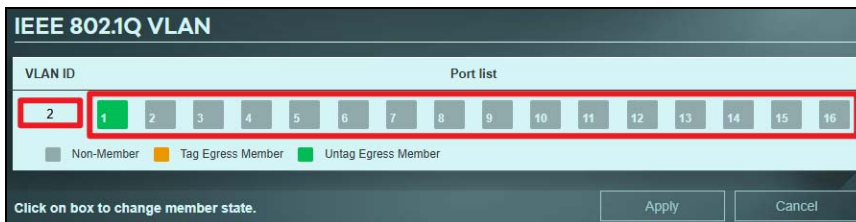

- 5 Click **Apply** to save the settings.

6.2.2 Setting Port VID

Use PVID to add a tag to incoming untagged frames received on that port so that the frames are forwarded to the VLAN group that the tag defines.

In the example network, configure 2 as the port VID (**PVID**) on port 1 (**P1**) so that any untagged frames received on that port get sent to **VLAN 2**.

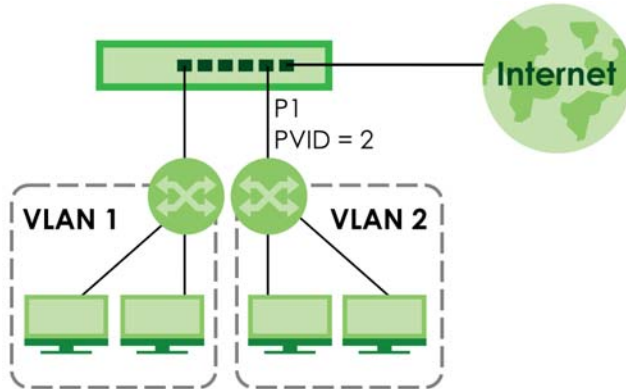
Figure 40 Initial Setup Network Example: Port VID

- 1 Click **VLAN** in the navigation panel.
- 2 Enter 2 in the **PVID** field for port 2 and click **Apply** to save your changes back to the Switch.

6.3 Upgrade Firmware on the Switch

Upload the firmware to the Switch for feature enhancements.

- 1 Download the firmware file at www.zyxel.com in a compressed file. Decompress the file.
- 2 Click **Management** in the navigation panel and click the **Firmware Upgrade** button.
- 3 You will not be able to configure other settings during the firmware upgrade process to avoid system crashes on the Switch. Click **OK**.
- 4 Type the path and file name of the firmware file you wish to upload to the Switch in the text box or click **path** to locate it. After you select the firmware file, click the **Upgrade** button to load the new firmware.

The screenshot shows a dialog box titled 'Firmware Upgrade'. It contains a text input field with the placeholder text 'Please select a file' and an orange button labeled 'path'. Below the input field are two buttons: 'Upgrade' and 'Cancel'. At the bottom of the dialog, there is a warning message: 'Please wait some times. Please do not power off, or unplug Ethernet cable during the upgrade...'

- 5 After a successful upload, the system will reboot, and you will need to log into the Switch again. Click **OK**.

6.4 Back up a Configuration File

Back up a configuration file in case you want to return to your previous settings.

- 1 Click **Management** in the navigation panel and click the **Backup** button.
- 2 Specify the location where you want to save the backup file. The default filename is **switch_cfg.bin**.
- 3 Click the **Save** button to save and store your current Switch settings.

6.5 Restore Configuration

You can upload a previously saved configuration file from your computer to your Switch to restore that previous configuration.

- 1 Click **Management** in the navigation panel.
- 2 Click **path** and select a .bin file to restore.

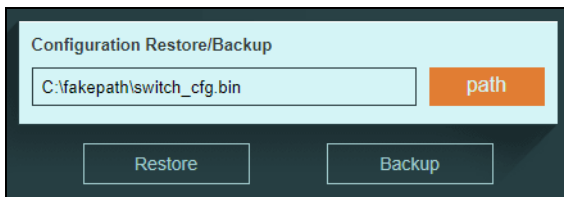

- 3 Click **Restore**. The following message appears after a successful restore.
- 4 Reboot the Switch.

6.6 Power over Ethernet (PoE) Configuration

This example is for PoE models.

See [Figure 1.3.1 on page 11](#) for an example of using PoE to power devices.

Before connecting devices that require PoE to the PoE ports, PD (Powered Devices), you must enable PoE on those ports.

- 1 Click **Port** in the navigation panel.
- 2 Go to **Port Setting**, select **Enable** for ports that will supply power to PDs in the **PoE** field, and click **Apply** to save your changes.

The screenshot shows the configuration interface for a switch. At the top, there are tabs for System, Port, VLAN, and Management. The 'Port' tab is selected. Below the tabs, there is a section for 'Loop Detection / Prevention' with a dropdown menu set to 'Off' and an 'Apply' button. Below that is the 'Port Setting' section, which contains a table with 16 rows representing ports 1 through 16. The table has five columns: Port, State, Speed/Duplex, Flow Control, and PoE. The PoE column is highlighted with a red border. All ports are configured with State: Enable, Speed/Duplex: Auto, Flow Control: Enable, and PoE: Enable.

Port	State	Speed/Duplex	Flow Control	PoE
1	Enable	Auto	Enable	Enable
2	Enable	Auto	Enable	Enable
3	Enable	Auto	Enable	Enable
4	Enable	Auto	Enable	Enable
5	Enable	Auto	Enable	Enable
6	Enable	Auto	Enable	Enable
7	Enable	Auto	Enable	Enable
8	Enable	Auto	Enable	Enable
9	Enable	Auto	Enable	Enable
10	Enable	Auto	Enable	Enable
11	Enable	Auto	Enable	Enable
12	Enable	Auto	Enable	Enable
13	Enable	Auto	Enable	Enable
14	Enable	Auto	Enable	Enable
15	Enable	Auto	Enable	Enable
16	Enable	Auto	Enable	Enable

- After connecting the PDs to the **PoE** ports, you can go to the **System** screen to check the amount of power the PDs are consuming (**PoE Status**), the maximum power the Switch can provide (**PoE Total Power**), and so on. See [Section 7.2 on page 46](#).

Note: The Switch allocates power to PDs in the order that they were connected. When the total power requested by the PDs exceeds the total PoE power budget on the Switch, the last PD connected to the Switch will not be powered up.

System Port VLAN Management

System Information

Model Name	Device Name	Firmware Version	Loop Status	System Up Time
GS1100-16EP	GS1100-16EP	V1.00(ACRO.0)B3	Normal	1 h 25 m 38 s

MAC Address	IP Address	Subnet Mask	Gateway
F00000000000	192.168.1.3	255.255.255.0	0.0.0.0

PoE Total Power	PoE Total Power Left	PoE MAX LED Power
135W	135W	128W

Per Port Status

Port	Link Status	Tx(Pkts)	Rx(Pkts)	Loop Status	PoE Status (W)
1	Down	23,099	39,667	Normal	0
2	Down	0	0	Normal	0
3	Down	0	0	Normal	0
4	Down	0	0	Normal	0
5	Down	0	0	Normal	0
6	Down	0	0	Normal	0
7	Down	0	0	Normal	0
8	Down	0	0	Normal	0
9	1000 Mbps	40,078	25,943	Normal	0
10	Down	0	0	Normal	0
11	Down	0	0	Normal	0
12	Down	0	0	Normal	0
13	Down	0	0	Normal	0
14	Down	0	0	Normal	0
15	Down	0	0	Normal	0
16	Down	0	0	Normal	0

Clear Refresh

PART II

Technical Reference

CHAPTER 7

System

7.1 Overview

This chapter describes the screens for system status, and port details.

7.2 System Screen

The **System** screen displays when you log into the Switch or click **System** at the top of the Web Configurator. The **System** screen displays the Switch's general device information, PoE status, and the port statistics.

Figure 41 System (PoE Model)

The screenshot shows the 'System' tab selected in the top navigation bar. Below the navigation bar, there are four tabs: 'System', 'Port', 'VLAN', and 'Management'. The main content area is titled 'System Information' and contains several data blocks:

- System Information Summary:** Model Name: GS1100-16EP, Device Name: GS1100-16EP, Firmware Version: V1.00(ACRO.0)B3, Loop status: Normal, System Up Time: 1 h 26 m 53 s.
- Network Information:** MAC Address: [redacted], IP Address: 192.168.1.3, Subnet Mask: 255.255.255.0, Gateway: 0.0.0.0.
- PoE Status:** PoE Total Power: 135W, PoE Total Power Left: 135W, PoE MAX LED Power: 128W.
- Per Port Status Table:**

Port	Link status	Tx(Pkts)	Rx(Pkts)	Loop status	PoE status (W)
1	Down	23,099	39,667	Normal	0
2	Down	0	0	Normal	0
3	Down	0	0	Normal	0
4	Down	0	0	Normal	0
5	Down	0	0	Normal	0
6	Down	0	0	Normal	0
7	Down	0	0	Normal	0
8	Down	0	0	Normal	0
9	1000 Mbps	40,076	25,943	Normal	0
10	Down	0	0	Normal	0
11	Down	0	0	Normal	0
12	Down	0	0	Normal	0
13	Down	0	0	Normal	0
14	Down	0	0	Normal	0
15	Down	0	0	Normal	0
16	Down	0	0	Normal	0

At the bottom of the screen, there are 'Clear' and 'Refresh' buttons.

The following table describes the labels in this screen.

Table 16 System

LABEL	DESCRIPTION
System Information	
Model Name	This field displays the model name of this Switch.
Device Name	<p>This field displays the name used to identify the Switch on any network.</p> <p>The device name is a link that you can click to open a screen where you can change the name. Enter a descriptive name of up to 14 characters. Also, spaces and the following special characters listed in the brackets ['" ` < ^ \$ & ; \ / : * ? '] are not allowed.</p> <p>Note: You must enter a descriptive name to identify the Switch.</p>
Firmware Version	<p>This field displays the version number and date of the firmware the Switch is currently running.</p> <p>The firmware on each Switch is identified by the firmware trunk version, followed by a unique code which identifies the model, and then the release number after the period. For example, V1.00 (ACRL.0) is a firmware for the 1.00 version trunk, the ACRL code identifies the GS1100-16 model, and '.0' is the first firmware release for the model.</p>
Loop Status	It displays Loop when the Switch detects a loop on the port. Otherwise, it displays Normal .
System Up Time	This field displays how long the Switch has been running since it last restarted or was turned on.
MAC Address	This field displays the MAC addresses of the Switch.
IP Address	<p>The Switch needs an IP address for it to be managed over the network. The factory default IP address is 192.168.1.3.</p> <p>This field displays the Switch's current IPv4 address.</p>
Subnet Mask	<p>The subnet mask specifies the network number portion of an IP address. The factory default subnet mask is 255.255.255.0.</p> <p>This field displays the Switch's subnet mask.</p>
Gateway	This field displays the IP address of the default outgoing gateway in dotted decimal notation, for example 192.168.1.254.
PoE Total Power (PoE Model)	<p>This field displays the total power the Switch can provide to the connected PoE-enabled devices on the PoE ports.</p> <p>When the total power requested by the PoE-enabled devices exceeds the total PoE power budget on the Switch, the last PoE-enabled device connected to the Switch will not be powered up.</p> <p>For example, the first powered device connected to port 1 requires 40 W, the second one connected to port 2 requires 60 W, and the third one connected to port 3 requires 40 W. In this case, the total power consumption is 140 W which exceeds the maximum power the Switch can supply. Therefore, the third powered device will not be powered up as it was connected last.</p>
PoE Total Power Left (PoE Model)	This field displays the amount of power the Switch can still provide for PoE.
PoE MAX LED Power (PoE Model)	This field displays 95% of the total power supply budget supported by the Switch. The PoE MAX LED on the Switch lights up when the PoE total power supply reaches this wattage.
Per Port Status	
Port	This identifies the Ethernet port on the Switch.
Link status	This field displays the current status or speed of each port. Done indicates that there is no connection to the port.
TX(Pkts)	This field shows the number of transmitted frames on this port.
RX(Pkts)	This field shows the number of received frames on this port.

Table 16 System (continued)

LABEL	DESCRIPTION
Loop Status	<p>This field displays Loop when the Switch detects a loop on this port. The action taken depends on whether Loop Detection or Loop Prevention is enabled on the Port screen.</p> <p>When Loop Detection is enabled:</p> <p>If two ports on the Switch are involved in a loop, both ports are marked as Loop, and their LINK/ACT LEDs blink slowly once per second. These ports continue to receive and forward packets.</p> <p>When Loop Prevention is enabled:</p> <p>If two ports on the Switch are involved in a loop, the port with the higher number is marked as Loop and stops receiving packets, and its LINK/ACT LED blinks slowly once per second. The port with lower number remains Normal and continue to receive and forward packets. For example, if both port 1 and port 2 are part of a loop, port 2 is blocked.</p>
PoE (W) (PoE Model)	This field displays the amount of power the Switch is currently supplying to the PoE-enabled device connected to the port.
Clear	Click this button to clear the statistics in this screen.
Refresh	Click this button to update the information in this screen.

CHAPTER 8

Port

8.1 Overview

This chapter introduces and shows you how to use loop detection and prevention to prevent loops in your network. In addition, you can configure transmission speed, flow control, port isolation, and PoE on a port.

8.1.1 Loop

A switch loop happens if there is more than one connection between two ports on the same switch or between two switches connected together. If this happens, broadcasts are continually rebroadcast and could flood the network. You must break the loop by stopping multiple paths between two switch ports.

Figure 42 The Switch Has Two Ports Connected with the Same Cable

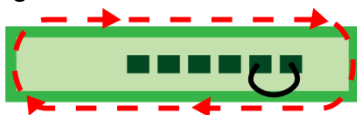

Figure 43 The Connected Switch Has Two Ports Connected with the Same Cable

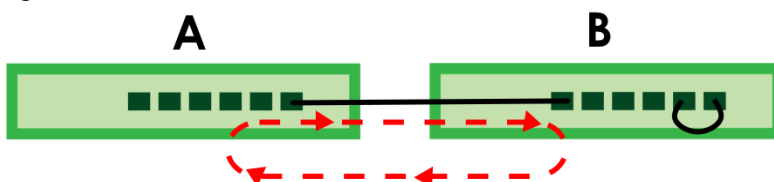
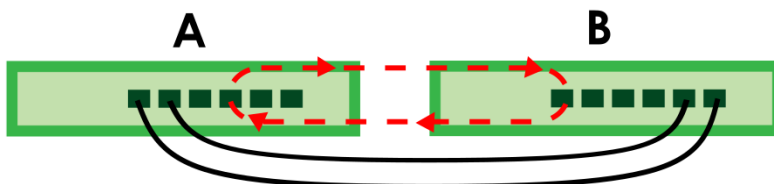

Figure 44 Two Connections between Switches without using the Spanning Tree Protocol (STP)



8.1.2 Port Isolation

Port isolation means that each port can only communicate with the uplink (out-going) port and cannot communicate with each other. All incoming ports are selected while only the uplink port is selected. An uplink port is a port through which a data packet leaves. An incoming port is a port through which a data packet enters. This option is the most limiting but also the most secure.

Figure 45 Port Isolation

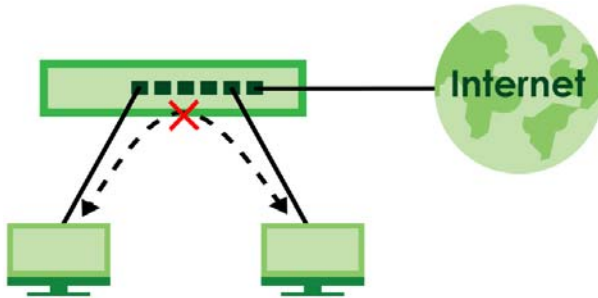

For example, if you have computers grouped together in a VLAN that communicates with servers in other networks. These computers have no need to communicate together, so it is best to block unwanted communication.

Note: You cannot configure port isolation settings and link aggregation settings on the same port.

8.2 Port Settings

Click **Port** in the navigation panel to open the following screen.

Figure 46 Port

The screenshot shows a web-based configuration interface for a switch. At the top, there are tabs for 'System', 'Port', 'VLAN', and 'Management', with 'Port' being the active tab. Below the tabs, there are two main sections: 'Loop Detection / Prevention' and 'Port Setting'.

The 'Loop Detection / Prevention' section has a dropdown menu set to 'Off' and an 'Apply' button below it.

The 'Port Setting' section contains a table with 16 rows, one for each port. Each row has five columns: 'Port', 'State', 'Speed/Duplex', 'Flow Control', and 'PoE'. All ports are configured with 'Enable' for State, 'Auto' for Speed/Duplex, 'Enable' for Flow Control, and 'Enable' for PoE.

Port	State	Speed/Duplex	Flow Control	PoE
1	Enable	Auto	Enable	Enable
2	Enable	Auto	Enable	Enable
3	Enable	Auto	Enable	Enable
4	Enable	Auto	Enable	Enable
5	Enable	Auto	Enable	Enable
6	Enable	Auto	Enable	Enable
7	Enable	Auto	Enable	Enable
8	Enable	Auto	Enable	Enable
9	Enable	Auto	Enable	Enable
10	Enable	Auto	Enable	Enable
11	Enable	Auto	Enable	Enable
12	Enable	Auto	Enable	Enable
13	Enable	Auto	Enable	Enable
14	Enable	Auto	Enable	Enable
15	Enable	Auto	Enable	Enable
16	Enable	Auto	Enable	Enable

At the bottom right of the 'Port Setting' section, there are two buttons: 'Advanced Setting' and 'Apply'.

The following table describes the labels in this screen.

Table 17 Port

LABEL	DESCRIPTION
Storm Control	
Loop Detection / Prevention	<p>Select Loop Detection to allow the Switch to monitor for network loops. Alerts appear on the LINK/ACT LEDs (see LEDs) and in the System screen in Web Configurator (see Loop Status).</p> <p>Select Loop Prevention to allow the Switch to automatically block traffic on a port if a loop is detected on that port. The port becomes active when the loop disappears. See Loop Status for details.</p> <p>Select Off to disable this feature.</p>
Apply	Click this button to save your changes to the Switch.
Port Setting	
Port	This identifies the Ethernet port on the Switch.
State	Select Enable to enable the port or Disable to disable it.
Speed/Duplex	<p>Select the speed of the Ethernet connection on this port.</p> <p>The options are:</p> <ul style="list-style-type: none"> • Auto (default) • 10M • 100M • 1000M <p>Select Auto (auto-negotiation) to allow one port to negotiate with a peer port automatically to obtain the connection speed that both ends support. When auto-negotiation is turned on, a port on the Switch negotiates with the peer automatically to determine the connection speed. If the peer port does not support auto-negotiation or turns off this feature, the Switch determines the connection speed by detecting the signal on the cable. When the Switch's auto-negotiation is turned off, a port uses the pre-configured speed when making a connection, therefore requiring you to make sure that the settings of the peer port are the same in order to connect.</p>
Flow Control	<p>A concentration of traffic on a port decreases port bandwidth and overflows buffer memory causing packet discards and frame losses. Flow Control is used to regulate transmission of signals to match the bandwidth of the receiving port.</p> <p>The Switch uses IEEE 802.3x flow control. IEEE802.3x flow control is used in full duplex mode to send a pause signal to the sending port, causing it to temporarily stop sending signals when the receiving port memory buffers fill.</p> <p>Back Pressure flow control is typically used in half duplex mode to send a "collision" signal to the sending port (mimicking a state of packet collision) causing the sending port to temporarily stop sending signals and resend later. Select the check box to enable it.</p>
PoE (PoE Model)	Select Enable to provide power to a PoE-enabled device connected to the port or Disable so the port cannot receive power from the Switch. See Section 1.3.1 on page 11 for more information on PoE.
Advanced Settings	Click this button to set up Port Isolation .
Apply	Click this button to save your changes to the Switch.

8.2.1 Advanced Settings

Click **Advanced Settings** to open the following screen.

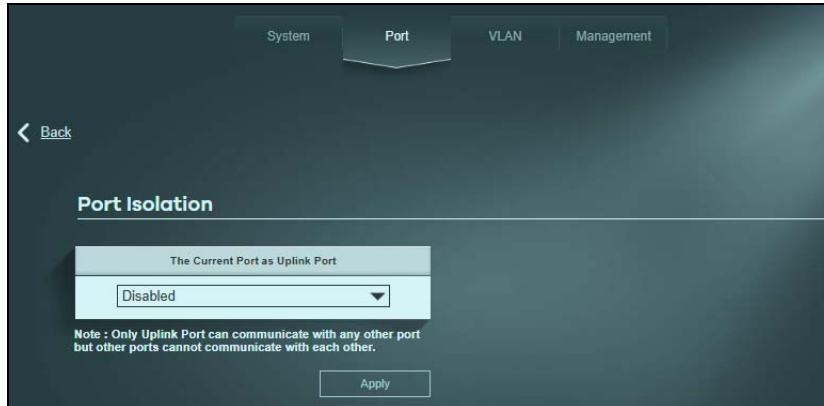
Figure 47 Port > Advanced Settings

The following table describes the labels in this screen.

Table 18 Port > Advanced Settings

LABEL	DESCRIPTION
Back	Click this button to return to the main Port (previous) screen.
Port Isolation	
The Current Port as Uplink Port	Select a port to be the uplink (out-going) port. Each port can only communicate with the uplink port and cannot communicate with each other. All incoming ports are selected while only the uplink port is selected. See Section 8.1.2 on page 49 for more details. Otherwise, select Disabled .
Apply	Click this button to save your changes to the Switch.

CHAPTER 9

VLAN

9.1 Overview

The primary function of a VLAN is to separate network traffic. A host in one VLAN cannot communicate with a host in another VLAN. While hosts on the same VLAN can communicate, even if they are not on the same switch. A VLAN is like a virtual switch.

Advantages of putting hosts in separate VLANs:

- To limit the amount of broadcasts across the network.
- To hide a client's data from another client.

This chapter shows you how to configure VLAN settings.

9.1.1 IEEE 802.1Q Tagged VLANs

Each port on the Switch is capable of passing tagged (**T**) or untagged (**UT**) frames. To forward a frame from an 802.1Q VLAN-aware switch to an 802.1Q VLAN-unaware switch, the Switch first decides where to forward the frame and then strips off the VLAN tag (**VT**). To forward a frame from an 802.1Q VLAN-unaware switch to an 802.1Q VLAN-aware switch, the Switch first decides where to forward the frame, and then inserts a VLAN tag reflecting the incoming port's default VID. The default PVID is VLAN 1 for all ports, but this can be changed.

A broadcast frame (or a multicast frame for a multicast group that is known by the system) is duplicated only on ports that are members of the VID (except the incoming port itself), thus confining the broadcast to a specific domain.

Figure 48 Tagged VLAN

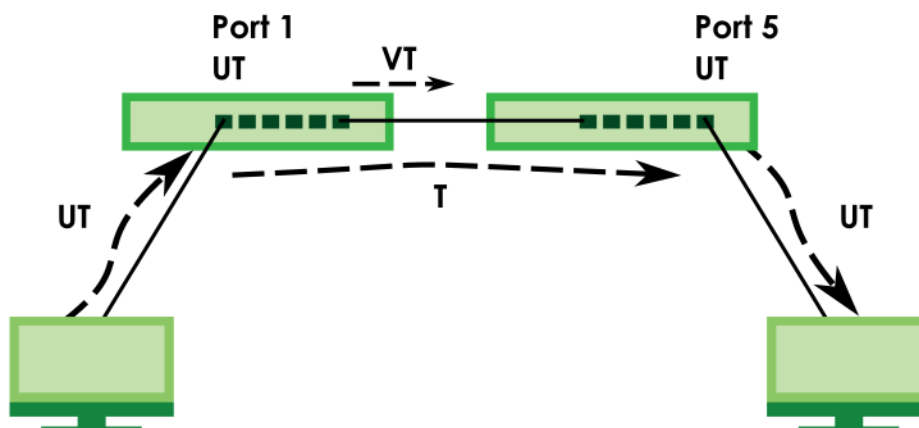

9.2 VLAN Settings

Use this screen to view and configure VLAN settings for the Switch. Click **VLAN** in the navigation panel.

9.2.1 VLAN Passthrough

VLAN Passthrough allows tagged VLAN traffic (**T**) to pass through the Switch without modifying or processing the VLAN tags. Select VLAN Passthrough on the **VLAN** screen when you want the Switch to act as an intermediate device, not responsible for VLAN segmentation. The Switch forwards tagged traffic as it is received.

Figure 49 VLAN Passthrough

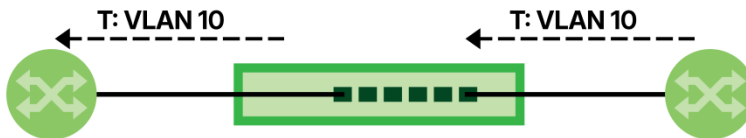

Figure 50 VLAN > VLAN passthrough



9.2.2 IEEE 802.1Q VLAN

Use this screen to view and configure PVID and VLAN settings for the Switch. Select **IEEE 802.1Q VLAN** on the **VLAN** screen to open the following screen.

Note: You could block yourself (and all others) from managing the Switch if you remove all ports from VLAN1 and you do not configure other VLAN groups. In case this happens, reset the Switch to the default settings (see [Section 4.5 on page 36](#) for more information).

Figure 51 VLAN > IEEE 802.1Q VLAN

The following table describes the labels in this screen.

Table 19 VLAN > IEEE 802.1Q VLAN

LABEL	DESCRIPTION
PVID	
Port	This field displays the port number.
PVID	A PVID (Port VLAN ID) is a tag that adds to incoming untagged frames received on a port so that the frames are forwarded to the VLAN group that the tag defines. Enter a number between 1 and 4094 as the port VLAN ID.
Apply	Click this button to save your PVID settings to the Switch.
VLAN Config	This shows the 802.1Q VLANs you have on the Switch.
VLAN ID	This is the ID number of the VLAN group.
Port List	This displays the ports that are participating in a VLAN. A tagged port is orange, an untagged port is green and ports not participating in a VLAN are gray. Multiple ports in a VLAN can be configured as tagged or untagged or not participating. A port is a 'tagged port' when the interface is expecting frames containing VLAN tags. An example of this is when the sender will send a frame with a VLAN tag. The receiving switch will see the VLAN tag, and if the VLAN is allowed, it will forward the frame.
Modify	Click Modify to edit the VLAN settings.
Delete	Click Delete to remove the VLAN group. You cannot delete the default VLAN.
Create New VLAN	Click this button to configure a new IEEE 802.1Q VLAN for the Switch.

CHAPTER 10

Management

10.1 Overview

This chapter explains how to use the **Management** screen to configure settings on the Switch, such as login password change, firmware upgrade, configuration backup and restore, system reset or reboot, IP address change, and so on.

10.1.1 IEEE 802.3az Energy Efficient Ethernet (EEE)

IEEE 802.3az allows both sides of a link to support EEE. When there is no traffic, the port enters Low Power Idle (LPI) mode. LPI mode turns off some functions of the physical layer (becomes quiet) to save power. Periodically the port transmits a REFRESH signal to allow the link partner to keep the link alive. When there is traffic to be sent, a WAKE signal is sent to the link partner to return the link to active mode.

10.2 Management Settings

Use this screen to upload the latest firmware, upload a stored device configuration file, save your configurations for later use, change the administrator system password, change the IP address, enable DHCP client, or reboot/reset the system.

An administrator is someone who can both view and configure Switch changes. The default administrator password is on the device label.

Click **Management** in the navigation panel to open the following screen.

Figure 52 Management

The following table describes the labels in this screen.

Table 20 Management

LABEL	DESCRIPTION
Device Setting	
Reset	Click this button to clear all Switch configuration information you configured and return to the factory defaults. If you want to access the Switch Web Configurator again, you may need to change the IP address of your computer to be in the same subnet as that of the default IP address.
Reboot	Click this button to restart the Switch without physically turning the power off.
Firmware Upgrade	Click this button to upgrade the latest firmware to the Switch.
DHCP Client	Select Enable if you have a DHCP server that can assign the Switch an IP address, subnet mask, a default gateway IP address and a domain name server IP address automatically. Otherwise, select Disable .
IP Address	Enter the IP address of your Switch in dotted decimal notation, for example, 192.168.1.3. This is the IP address of the Switch in an IP routing domain.
Subnet Mask	Enter the IP subnet mask of an IP routing domain in dotted decimal notation, for example, 255.255.255.0.

Table 20 Management (continued)

LABEL	DESCRIPTION
Gateway	Enter the IP address of the default outgoing gateway in dotted decimal notation, for example 192.168.1.254.
Apply	Click this button to save your changes for DHCP Client , IP Address , Subnet Mask , and Gateway to the Switch.
HTTP Timeout (Minutes)	Enter how many minutes (from 1 to 30) a session can be left idle before the session times out. After it times out, you have to log in with your password again. A very long timeout setting may have security risks.
Apply	Click this button to save your changes for HTTP Timeout to the Switch.
IEEE 802.3az EEE	Select Enable to activate Energy Efficient Ethernet globally. Otherwise, select Disable .
Apply	Click this button to save your changes for IEEE 802.3az EEE to the Switch.
LED ECO Mode	Select Enable to turn off all the Switch LINK/ACT port LEDs. Select Disable to turn on all the Switch LINK/ACT port LEDs.
Apply	Click this button to save your changes to the Switch.
Configuration Restore/Backup	Enter the path and file name of the configuration file you wish to restore in the text box or click path to locate it.
Restore	Click Restore to restore a previously saved configuration from your computer to the Switch. Note: "config" is the name of the configuration file on the Switch, so your backup configuration file is automatically renamed when you restore using this screen.
Backup	Click Backup to save and store your current Switch settings.
Change Password	
Old Password	Enter the existing system password.
New Password	Enter your new system password using keyboard characters (a – z, A – Z, and 0 – 9). The password must be 8 to 15 characters long
Confirm Password	Reenter your new system password for confirmation.
Apply	Click this button to save your changes for Change Password to the Switch.

10.2.1 Firmware Upgrade

Firmware upgrades contain bug fixes and fixes for security vulnerabilities. It is recommended to keep the Switch's firmware up to date.

Make sure you have downloaded (and unzipped) the correct model firmware and version to your computer before uploading to the Switch.

Be sure to upload the correct model firmware as uploading the wrong model firmware may damage your device.

Do NOT disconnect or turn off power to the Switch while firmware upload is in progress!

The following message will appear after you click the **Firmware Upgrade** button. You will not be able to configure other settings during the firmware upgrade process to avoid system crashes on the Switch. Click **OK**.

Figure 53 Firmware Upgrade Message

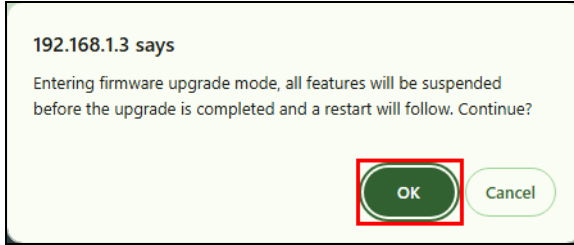

Enter the path and file name of the firmware file you wish to upload to the Switch in the text box or click **path** to locate it. After you select the firmware file, click the **Upgrade** button to load the new firmware.

Figure 54 Firmware Upgrade Path

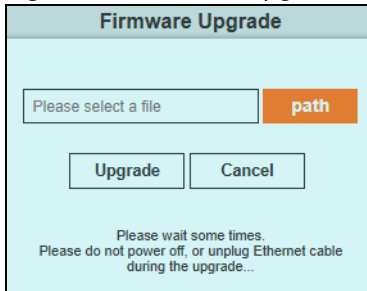

After a successful upload, the system will reboot, and you will need to log into the Switch again.

Figure 55 Firmware Upgrade Confirmation

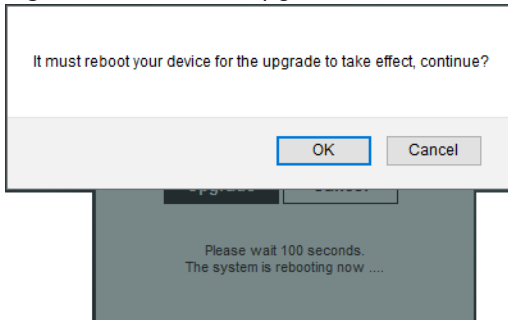

If you click the **Cancel** button in the **Firmware Upgrade** page, the Switch will reboot, and you will be directed to the login screen.

CHAPTER 11

Troubleshooting

This chapter offers some suggestions to solve problems you might encounter. The potential problems are divided into the following categories.

- [Power, Hardware Connections, and LEDs](#)
- [Switch Access and Login](#)
- [Switch Configuration](#)
- [PoE Supply](#)
- [Improper Network Cabling and Topology](#)

11.1 Power, Hardware Connections, and LEDs

[The Switch does not turn on. None of the LEDs turn on.](#)

- 1 Make sure you are using the power adapter or cord included with the Switch.
- 2 Make sure the Switch is turned on (for GS1100-10HP Revision A1 only).
- 3 Make sure the power adapter or cord is connected to the Switch and plugged in to an appropriate power source. Make sure the power source is turned on.
- 4 Turn the Switch off and on (for GS1100-10HP Revision A1 only).
- 5 Disconnect and re-connect the power adapter or cord to the Switch.
- 6 If the problem continues, contact the vendor.

[One of the LEDs does not behave as expected.](#)

- 1 Make sure you understand the normal behavior of the LED. See [Section 3.3 on page 30](#).
- 2 Check the hardware connections. See [Section 3.1 on page 21](#).
- 3 Inspect your cables for damage. Contact the vendor to replace any damaged cables.
- 4 Turn the Switch off and on (for GS1100-10HP Revision A1 only).

- 5 Disconnect and re-connect the power adapter or cord to the Switch.
- 6 If the problem continues, contact the vendor.

The **PWR LED** on the front panel does not light up.

- Check the connections from your Switch to the power source. Make sure you are using the supplied power cord and that you are using an appropriate power source. Refer to the product specifications.
- Make sure the power source is turned on and that the Switch is receiving sufficient power.
- If these steps fail to correct the problem, contact your local distributor for assistance.

The **LNK/ACT, 1G** or **10/100** LED does not light up when a device is connected.

- Verify that the attached device(s) is turned on and properly connected to your Switch.
- Make sure the network adapters are working on the attached devices.
- Verify that proper network cable type is used and its length does not exceed 100 meters. For more information on network cable types, see [Table 8 on page 22](#).

A loop is detected. (For UM+ Model)

- 1 To restore a port in a loop state, disconnect it, check the network connections, and reconnect it.
- 2 You can log into the Web Configurator. Go to **System** in the Web Configurator to check your port status. Note that you can do this when you enable **Loop Detection / Prevention** (default) in the **Port** screen.

11.2 Switch Access and Login

I forgot the IP address for the Switch.

- 1 The default IP address is 192.168.1.3.
- 2 If this does not work, you have to reset the Switch to its factory defaults. See [Section 4.5 on page 36](#).

I forgot the password.

- 1 The default password is on the device label.
- 2 If this does not work, you have to reset the Switch to its factory defaults. See [Section 4.5 on page 36](#).

I cannot see or access the Login screen in the Web Configurator.

- 1 Make sure you are using the correct IP address.
 - The default IP address is 192.168.1.3.
 - If you changed the IP address, use the new IP address.
 - If you changed the IP address and have forgotten it, see the troubleshooting suggestions for [I forgot the IP address for the Switch](#).
- 2 Check the hardware connections, and make sure the LEDs are behaving as expected. See [Section 3.3 on page 30](#).
- 3 Make sure your Internet browser does not block pop-up windows and has JavaScripts and Java enabled.
- 4 Make sure your computer is in the same subnet as the Switch. (If you know that there are routers between your computer and the Switch, skip this step.)
- 5 Reset the device to its factory defaults, and try to access the Switch with the default IP address. See [Section 3.1.5 on page 24](#).
- 6 If the problem continues, contact the vendor.

I can see the Login screen, but I cannot log in to the Switch.

- 1 Make sure you have entered the password correctly. The default password is on the device label.
- 2 Disconnect and re-connect the power cord to the Switch.
- 3 If this does not work, you have to reset the device to its factory defaults. See [Section 3.1.5 on page 24](#).

Pop-up Windows, JavaScripts and Java Permissions

In order to use the Web Configurator you need to allow the following:

- Web browser pop-up windows from your device.
- JavaScripts (enabled by default).
- Java permissions (enabled by default).

11.3 Switch Configuration

After upgrading firmware on the Switch, the login screen does not display.

When one of the following should happen during the firmware upgrade process, a failure may occur.

During the firmware upgrade process:

- The Switch loses power.
- The computer from which you uploaded the firmware file to the Switch is turned off.
- The Ethernet cable connecting the Switch and the computer comes loose. This is the computer from where you uploaded the firmware file to the Switch.

When any of the above occurs, and you are directed to the **Firmware Upgrade** screen, follow the steps below:

- 1 Make sure the power supply is sufficient in your environment.
- 2 Make sure your computer's Ethernet cable is securely connected to the Switch.
- 3 Select the firmware file that you tried to upload to the Switch before and try upgrading the firmware again in the **Firmware Upgrade** screen.
- 4 Wait for the firmware upgrade process to complete. After a successful upload, the system will reboot, and you will need to log into the Switch again.

11.4 PoE Supply

My Powered Devices (PDs) are not receiving power.

- 1 Check the PoE usage of the Switch through the following methods. When the total power requested by the PoE-enabled devices exceeds the total PoE power budget, the last PoE-enabled device connected to the Switch will not be powered up. You can add another PoE-capable Switch for additional PDs.
 - Check the **PoE MAX** LED on the front panel of your Switch.
 - Check the PoE LED on the port to which your PD is connected. Make sure that the port is supplying power to the PD.
- 2 Make sure the PDs are functional.
 - Check whether the PDs are malfunctioning. See your PDs user's guide for more information.
 - Make sure the connected PDs support PoE.
 - If the connected PDs do not fully comply with the Switch's supported PoE standard (See [Section 3.1.4 on page 23](#) for the Switch's supported PoE standards), replace the PDs with PoE standard-compliant devices for better compatibility.

- 3 Make sure the Ethernet cables connected to the PDs are functional.
 - Use the correct type of Ethernet cable for the corresponding PoE standard you are using. See [Section 3.1.4 on page 23](#) for the Switch's supported PoE standards and supported Ethernet cables.
 - Check whether the Ethernet cables are malfunctioning. Use functional Ethernet cables to reconnect the Switch to the PDs.
- 4 Disconnect and re-connect the power adapter to the Switch.
- 5 If the problem continues, contact Zyxel technical support.

11.5 Improper Network Cabling and Topology

Improper network cabling or topology setup is a common cause of poor network performance or even network failure.

Figure 56 Troubleshooting Improper Network Cabling and Topology

PROBLEM	CORRECTIVE ACTION
Faulty cables	Using faulty network cables may affect data rates and have an impact on your network performance. Replace with new standard network cables.
Non-standard network cables	Non-standard cables may increase the number of network collisions and cause other network problems that affect your network performance. Refer to Table 8 on page 22 for more information on network cable types.
Cabling Length	If you use longer cables than are needed, transmission quality may be affected. The network cables should not be longer than the limit of 100 meters.
Too many hubs between the computers in the network	Too many hubs (or repeaters) between the connected computers in the network may increase the number of network collision or other network problems. Remove unnecessary hubs from the network.
A loop in the data path	A data path loop forms when there is more than one path or route between two networked computers. This results in broadcast storms that will severely affect your network performance. Make sure there are no loops in your network topology.

APPENDIX A

Customer Support

In the event of problems that cannot be solved by using this manual, you should contact your vendor. If you cannot contact your vendor, then contact a Zyxel office for the region in which you bought the device.

For Zyxel Communications offices, see <https://service-provider.zyxel.com/global/en/contact-us> for the latest information.

For Zyxel Networks offices, see <https://www.zyxel.com/index.shtml> for the latest information.

Please have the following information ready when you contact an office.

Required Information

- Product model and serial number.
- Warranty Information.
- Date that you received your device.
- Brief description of the problem and the steps you took to solve it.

Corporate Headquarters (Worldwide)

Taiwan

- Zyxel Communications (Taiwan) Co., Ltd.
- <https://www.zyxel.com>

Asia

China

- Zyxel Communications Corporation–China Office
- <https://www.zyxel.com/cn/sc>

India

- Zyxel Communications Corporation–India Office
- <https://www.zyxel.com/in/en-in>

Kazakhstan

- Zyxel Kazakhstan
- <https://www.zyxel.com/ru/ru>

Korea

- Zyxel Korea Co., Ltd.
- <http://www.zyxel.kr/>

Malaysia

- Zyxel Communications Corp.
- <https://www.zyxel.com/global/en>

Philippines

- Zyxel Communications Corp.
- <https://www.zyxel.com/global/en>

Singapore

- Zyxel Communications Corp.
- <https://www.zyxel.com/global/en>

Taiwan

- Zyxel Communications (Taiwan) Co., Ltd.
- <https://www.zyxel.com/tw/zh>

Thailand

- Zyxel Thailand Co., Ltd.
- <https://www.zyxel.com/th/th>

Vietnam

- Zyxel Communications Corporation–Vietnam Office
- <https://www.zyxel.com/vn/vi>

Europe

Belarus

- Zyxel Communications Corp.
- <https://www.zyxel.com/ru/ru>

Belgium (Netherlands)

- Zyxel Benelux
- <https://www.zyxel.com/nl/nl>
- <https://www.zyxel.com/fr/fr>

Bulgaria

- Zyxel Bulgaria

- <https://www.zyxel.com/bg/bg>

Czech Republic

- Zyxel Communications Czech s.r.o.
- <https://www.zyxel.com/cz/cs>

Denmark

- Zyxel Communications A/S
- <https://www.zyxel.com/dk/da>

Finland

- Zyxel Communications
- <https://www.zyxel.com/fi/fi>

France

- Zyxel France
- <https://www.zyxel.com/fr/fr>

Germany

- Zyxel Deutschland GmbH.
- <https://www.zyxel.com/de/de>

Hungary

- Zyxel Hungary & SEE
- <https://www.zyxel.com/hu/hu>

Italy

- Zyxel Communications Italy S.r.l.
- <https://www.zyxel.com/it/it>

Norway

- Zyxel Communications A/S
- <https://www.zyxel.com/no/no>

Poland

- Zyxel Communications Poland
- <https://www.zyxel.com/pl/pl>

Romania

- Zyxel Romania
- <https://www.zyxel.com/ro/ro>

Russian Federation

- Zyxel Communications Corp.
- <https://www.zyxel.com/ru/ru>

Slovakia

- Zyxel Slovakia
- <https://www.zyxel.com/sk/sk>

Spain

- Zyxel Iberia
- <https://www.zyxel.com/es/es>

Sweden

- Zyxel Communications A/S
- <https://www.zyxel.com/se/sv>

Switzerland

- Studerus AG
- <https://www.zyxel.com/ch/de-ch>
- <https://www.zyxel.com/fr/fr>

Turkey

- Zyxel Turkey A.S.
- <https://www.zyxel.com/tr/tr>

UK

- Zyxel Communications UK Ltd.
- <https://www.zyxel.com/uk/en-gb>

Ukraine

- Zyxel Ukraine
- <https://www.zyxel.com/ua/uk-ua>

South America

Argentina

- Zyxel Communications Corp.
- <https://www.zyxel.com/co/es-co>

Brazil

- Zyxel Communications Brasil Ltda.

- <https://www.zyxel.com/br/pt>

Colombia

- Zyxel Communications Corp.
- <https://www.zyxel.com/co/es-co>

Ecuador

- Zyxel Communications Corp.
- <https://www.zyxel.com/co/es-co>

South America

- Zyxel Communications Corp.
- <https://www.zyxel.com/co/es-co>

Middle East

Israel

- Zyxel Communications Corp.
- <https://il.zyxel.com>

North America

USA

- Zyxel Communications, Inc. – North America Headquarters
- <https://www.zyxel.com/us/en-us>

APPENDIX B

Legal Information

Copyright

Copyright © 2026 Zyxel and/or its affiliates. All rights reserved.

The contents of this publication may not be reproduced in any part or as a whole, transcribed, stored in a retrieval system, translated into any language, or transmitted in any form or by any means, electronic, mechanical, magnetic, optical, chemical, photocopying, manual, or otherwise, without the prior written permission of Zyxel Communications Corporation.

Published by Zyxel and/or its affiliates. All rights reserved.

Disclaimer

Zyxel does not assume any liability arising out of the application or use of any products, or software described herein. Neither does it convey any license under its patent rights nor the patent rights of others. Zyxel further reserves the right to make changes in any products described herein without notice. This publication is subject to change without notice.

Regulatory Notice and Statement (Class A)

Model List: GS1100-16, GS1100-24, GS1100-24E, GS1100-10HP (Revision B1), GS1100-16E, GS1100-16EP

United States of America



The following information applies if you use the product within USA area.

US Importer: Zyxel Communications, Inc, 1130 North Miller Street Anaheim, CA92806-2001, <https://www.zyxel.com/us/en/>

Federal Communications Commission (FCC) EMC Statement

- This device complies with Part 15 of FCC rules. Operation is subject to the following two conditions:
 - (1) This device may not cause harmful interference.
 - (2) This device must accept any interference received, including interference that may cause undesired operations.
- Changes or modifications not expressly approved by the party responsible for compliance could void the user's authority to operate the equipment.

- This equipment has been tested and found to comply with the limits for a Class A digital device, pursuant to part 15 of the FCC Rules. These limits are designed to provide reasonable protection against harmful interference when the equipment is operated in a commercial environment.
- This equipment generates, uses, and can radiate radio frequency energy and, if not installed and used in accordance with the instruction manual, may cause harmful interference to radio communications. Operation of this equipment in a residential area is likely to cause harmful interference in which case the user will be required to correct the interference at his own expense.

Canada

The following information applies if you use the product within Canada area.

Innovation, Science and Economic Development Canada ICES statement

CAN ICES(A)/NMB(A)

Europe and the United Kingdom



The following information applies if you use the product within the European Union and United Kingdom.

EMC statement

WARNING: This equipment is compliant with Class A of EN55032. In a residential environment this equipment may cause radio interference.

List of National Codes

COUNTRY	ISO 3166 2 LETTER CODE	COUNTRY	ISO 3166 2 LETTER CODE
Austria	AT	Liechtenstein	LI
Belgium	BE	Lithuania	LT
Bulgaria	BG	Luxembourg	LU
Croatia	HR	Malta	MT
Cyprus	CY	Netherlands	NL
Czech Republic	CZ	Norway	NO
Denmark	DK	Poland	PL
Estonia	EE	Portugal	PT
Finland	FI	Romania	RO
France	FR	Serbia	RS
Germany	DE	Slovakia	SK
Greece	GR	Slovenia	SI
Hungary	HU	Spain	ES
Iceland	IS	Sweden	SE
Ireland	IE	Switzerland	CH
Italy	IT	Turkey	TR
Latvia	LV	United Kingdom	GB

Notices

CLASS 1 LASER PRODUCT

APPAREIL À LASER DE CLASS 1

PRODUCT COMPLIES WITH 21 CFR 1040.10 AND 1040.11.

PRODUIT CONFORME SELON 21 CFR 1040.10 ET 1040.11.

Safety Warnings

- Do NOT use this product near water, for example, in a wet basement or near a swimming pool.
- Do NOT expose your device to dampness, dust or corrosive liquids.
- Do NOT store things on the device.
- Do NOT obstruct the device ventilation slots as insufficient airflow may harm your device. For example, do not place the device in an enclosed space such as a box or on a very soft surface such as a bed or sofa.
- There is a remote risk of electric shock from lightning: (1) Do not use the device outside, and make sure all the connections are indoors. (For indoor devices only) (2) Do not install or service this device during a thunderstorm.
- Connect ONLY suitable accessories to the device.
- Do NOT open the device or unit. Opening or removing covers can expose you to dangerous high voltage points or other risks. Only qualified service personnel should service or disassemble this device. Please contact your vendor for further information.
- Make sure to connect the cables to the correct ports.

- Place connecting cables carefully so that no one will step on them or stumble over them.
- Always disconnect all cables from this device before servicing or disassembling.
- Do NOT remove the plug and connect it to a power outlet by itself; always attach the plug to the power adaptor first before connecting it to a power outlet.
- Do NOT allow anything to rest on the power adaptor or cord and do NOT place the product where anyone can walk on the power adaptor or cord.
- Please use the provided or designated connection cables/power cables/adaptors. Connect it to the right supply voltage (for example, 120V AC in North America or 230V AC in Europe). If the power adaptor or cord is damaged, it might cause electrocution. Remove it from the device and the power source, repairing the power adaptor or cord is prohibited. Contact your local vendor to order a new one.
- CAUTION: RISK OF EXPLOSION IF BATTERY IS REPLACED BY AN INCORRECT TYPE, DISPOSE OF USED BATTERIES ACCORDING TO THE INSTRUCTION. Dispose them at the applicable collection point for the recycling of electrical and electronic device. For detailed information about recycling of this product, please contact your local city office, your household waste disposal service or the store where you purchased the product.
- Use ONLY power wires of the appropriate wire gauge for your device. Connect it to a power supply of the correct voltage.
- The PoE (Power over Ethernet) devices that supply or receive power and their connected Ethernet cables must all be completely indoors.
- The following warning statements apply, where the disconnect device is not incorporated in the device or where the plug on the power supply cord is intended to serve as the disconnect device,
 - For PERMANENTLY CONNECTED DEVICES, a readily accessible disconnect device shall be incorporated external to the device;
 - For PLUGGABLE DEVICES, the socket-outlet shall be installed near the device and shall be easily accessible.
- This device must be grounded by qualified service personnel. Never defeat the ground conductor or operate the device in the absence of a suitably installed ground conductor. Contact the appropriate electrical inspection authority or an electrician if you are uncertain that suitable grounding is available.
- If your device has an earthing screw (frame ground), connect the screw to a ground terminal using an appropriate AWG ground wire. Do this before you make other connections.
- If your device has no earthing screw, but has a 3-prong power plug, make sure to connect the plug to a 3-hole earthed socket.
- When connecting or disconnecting power to hot-pluggable power supplies, if offered with your system, observe the following guidelines:
 - Install the power supply before connecting the power cable to the power supply.
 - Unplug the power cable before removing the power supply.
 - If the system has multiple sources of power, disconnect power from the system by unplugging all power cables from the power supply.
- Do not put the device in a place that is humid, dusty or has extreme temperatures as these conditions may harm your device.
- Please refer to the device back label, datasheet, box specifications or catalog information for the power rating of the device and operating temperature.
- Do not leave a battery in an extremely high temperature environment or surroundings since it can result in an explosion or the leakage of flammable liquid or gas. (For devices with a battery)
- Do not subject a battery to extremely low air pressure since it may result in an explosion or the leakage of flammable liquid or gas. (For devices with a battery)
- Fuse Warning! Replace a fuse only with a fuse of the same type and rating. (For devices with a fuse)

- To avoid possible eye injury, do not look into an operating fiber-optic module's connector. (For devices with fiber)
- Complies with 21 CFR 1040.10 and 1040.11 except for conformance with IEC 60825-1 Ed. 3., as described in Laser Notice No. 56, dated May 8, 2019. (For devices with fiber)
- Conforme à 21 CFR 1040.10 et 1040.11 sauf pour la conformité à la norme CEI 60825-1 Ed. 3., comme décrit dans la notice laser Numéro 56 du 8 mai 2019. (For devices with fiber)
- CLASS 1 LASER PRODUCT & "IEC 60825-1:2014" (For devices with fiber)
- APPAREIL À LASER DE CLASS 1 (For devices with fiber)
- CLASS 1 CONSUMER LASER PRODUCT & "EN 50689:2021" (For devices with fiber)

Important Safety Instructions (For device with fan)

- 1 Warning! Energy Hazard. Remove all metal jewelry, watches, and so on from your hands and wrists before serving this device.
- 2 Do not open the Switch. Opening or removing covers can expose you to dangerous high voltage points or other risks.
- 3 Caution! The RJ-45 jacks are not used for telephone line connection.

- 4  Hazardous Moving Parts. Keep body parts away from fan blades.

- 5  Hot Surface. Do not touch.

- 1 Avertissement: Risque de choc électrique. Retirer tout bijoux en métal et votre montre de vos mains et poignets avant de manipuler cet appareil.

- 2 Attention: Les câbles RJ-45 ne doivent pas être utilisés pour les connections téléphoniques.

- 3 Ne pas ouvrir l'appareil. L'ouverture ou le retrait des couvercles peut vous exposer à des points comportant des tensions élevées ou à d'autres risques.

- 4  Mobilité des pièces détachées. S'assurer que les pièces détachées ne sont pas en contact avec les pales du ventilateur.

- 5  Surface brûlante. Ne pas toucher.

Environment Statement

Disposal and Recycling Information

The symbol below means that according to local regulations your product and/or its battery shall be disposed of separately from domestic waste. If this product is end of life, take it to a recycling station designated by local authorities. At the time of disposal, the separate collection of your product and/or its battery will help save natural resources and ensure that the environment is sustainable development.

Die folgende Symbol bedeutet, dass Ihr Produkt und/oder seine Batterie gemäß den örtlichen Bestimmungen getrennt vom Hausmüll entsorgt werden muss. Wenden Sie sich an eine Recyclingstation, wenn dieses Produkt das Ende seiner Lebensdauer erreicht hat. Zum Zeitpunkt der Entsorgung wird die

getrennte Sammlung von Produkt und/oder seiner Batterie dazu beitragen, natürliche Ressourcen zu sparen und die Umwelt und die menschliche Gesundheit zu schützen.

El símbolo de abajo indica que según las regulaciones locales, su producto y/o su batería deberán depositarse como basura separada de la doméstica. Cuando este producto alcance el final de su vida útil, llévelo a un punto limpio. Cuando llegue el momento de desechar el producto, la recogida por separado éste y/o su batería ayudará a salvar los recursos naturales y a proteger la salud humana y medioambiental.

Le symbole ci-dessous signifie que selon les réglementations locales votre produit et/ou sa batterie doivent être éliminés séparément des ordures ménagères. Lorsque ce produit atteint sa fin de vie, amenez-le à un centre de recyclage. Au moment de la mise au rebut, la collecte séparée de votre produit et/ou de sa batterie aidera à économiser les ressources naturelles et protéger l'environnement et la santé humaine.

Il simbolo sotto significa che secondo i regolamenti locali il vostro prodotto e/o batteria deve essere smaltito separatamente dai rifiuti domestici. Quando questo prodotto raggiunge la fine della vita di servizio portarlo a una stazione di riciclaggio. Al momento dello smaltimento, la raccolta separata del vostro prodotto e/o della sua batteria aiuta a risparmiare risorse naturali e a proteggere l'ambiente e la salute umana.

Symbolen innebär att enligt lokal lagstiftning ska produkten och/eller dess batteri kastas separat från hushållsavfallet. När den här produkten når slutet av sin livslängd ska du ta den till en återvinningsstation. Vid tiden för kasseringen bidrar du till en bättre miljö och mänsklig hälsa genom att göra dig av med den på ett återvinningsställe.



台灣

以下訊息僅適用於產品銷售至台灣地區

- 這是甲類的資訊產品，在居住的環境中使用時，可能會造成射頻干擾，在這種情況下，使用者會被要求採取某些適當的對策。
- 為避免電磁干擾，本產品不應安裝或使用於住宅環境。

安全警告 – 為了您的安全，請先閱讀以下警告及指示：





- 請勿將此產品接近水、火焰或放置在高溫的環境。
- 避免設備接觸
 - 任何液體 - 切勿讓設備接觸水、雨水、高濕度、污水腐蝕性的液體或其他水份。
 - 灰塵及污物 - 切勿接觸灰塵、污物、沙土、食物或其他不合適的材料。
- 雷雨天氣時，不要安裝或維修此設備。有遭受電擊的風險。
- 切勿重摔或撞擊設備，並勿使用不正確的電源變壓器。
- 若接上不正確的電源變壓器會有爆炸的風險。
- 請勿隨意更換產品內的電池。

- 如果更換不正確之電池型式，會有爆炸的風險，請依製造商說明書處理使用過之電池。
- 請將廢電池丟棄在適當的電器或電子設備回收處。
- 請勿將設備解體。
- 請勿阻礙設備的散熱孔，空氣對流不足將會造成設備損害。
- 請使用隨貨提供或指定的連接線 / 電源線 / 電源變壓器，將其連接到合適的供應電壓 (如：台灣供應電壓 110 伏特) 。
- 假若電源變壓器或電源變壓器的纜線損壞，請從插座拔除，若您還繼續插電使用，會有觸電死亡的風險。
- 請勿試圖修理電源變壓器或電源變壓器的纜線，若有毀損，請直接聯絡您購買的店家，購買一個新的電源變壓器。
- 請勿將此設備安裝於室外，此設備僅適合放置於室內。
- 請勿隨一般垃圾丟棄。
- 請參閱產品背貼上的設備額定功率。
- 請參考產品型錄或是彩盒上的作業溫度。
- 設備必須接地，接地導線不允許被破壞或沒有適當安裝接地導線，如果不確定接地方式是否符合要求可聯繫相應的電氣檢驗機構檢驗。
- 如果您提供的系統中有提供熱插拔電源，連接或斷開電源請遵循以下指導原則：
 - 先連接電源線至設備連，再連接電源。
 - 先斷開電源再拔除連接至設備的電源線。
 - 如果系統有多個電源，需拔除所有連接至電源的電源線再關閉設備電源。
- 產品沒有斷電裝置或者採用電源線的插頭視為斷電裝置的一部分，以下警語將適用：
 - 對永久連接之設備，在設備外部須安裝可觸及之斷電裝置；
 - 對插接式之設備，插座必須接近安裝之地點而且是易於觸及的。

About the Symbols

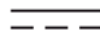
Various symbols are used in this product to ensure correct usage, to prevent danger to the user and others, and to prevent property damage. The meaning of these symbols are described below. It is important that you read these descriptions thoroughly and fully understand the contents.

Explanation of the Symbols

SYMBOL	EXPLANATION
	Alternating current (AC): AC is an electric current in which the flow of electric charge periodically reverses direction.
	Direct current (DC): DC is the unidirectional flow or movement of electric charge carriers.
	Earth; ground: A wiring terminal intended for connection of a Protective Earthing Conductor.
	Earth; ground: A wiring terminal intended for connection of a Functional Earthing Conductor.
	Class II equipment: The method of protection against electric shock in the case of class II equipment is either double insulation or reinforced insulation.

Viewing Certifications

Go to <http://www.zyxel.com> to view this product's documentation and certifications.

Zyxel Limited Warranty

Zyxel warrants to the original end user (purchaser) that this product is free from any defects in material or workmanship for a specific period (the Warranty Period) from the date of purchase. The Warranty Period varies by region. Check with your vendor and/or the authorized Zyxel local distributor for details about the Warranty Period of this product. During the warranty period, and upon proof of purchase, should the product have indications of failure due to faulty workmanship and/or materials, Zyxel will, at its discretion, repair or replace the defective products or components without charge for either parts or labor, and to whatever extent it shall deem necessary to restore the product or components to proper operating condition. Any replacement will consist of a new or re-manufactured functionally equivalent product of equal or higher value, and will be solely at the discretion of Zyxel. This warranty shall not apply if the product has been modified, misused, tampered with, damaged by an act of God, or subjected to abnormal working conditions.

Note

Repair or replacement, as provided under this warranty, is the exclusive remedy of the purchaser. This warranty is in lieu of all other warranties, express or implied, including any implied warranty of merchantability or fitness for a particular use or purpose. Zyxel shall in no event be held liable for indirect or consequential damages of any kind to the purchaser.

To obtain the services of this warranty, contact your vendor. You may also refer to the warranty policy for the region in which you bought the device at <https://www.zyxel.com/global/en/support/warranty-information>.

Registration

Register your product online at www.zyxel.com to receive email notices of firmware upgrades and related information.

Trademarks

The trademarks mentioned in this publication are used for identification purposes only and may be properties of their respective owners.

Regulatory Notice and Statement (Class B)

Model List: GS1100-10HP (Revision A1)

United States of America



The following information applies if you use the product within USA area.

US Importer: Zyxel Communications, Inc, 1130 North Miller Street Anaheim, CA92806-2001, <https://www.zyxel.com/us/en/>

Federal Communications Commission (FCC) EMC Statement

- This device complies with Part 15 of FCC rules. Operation is subject to the following two conditions:
 - (1) This device may not cause harmful interference.
 - (2) This device must accept any interference received, including interference that may cause undesired operations.
- Changes or modifications not expressly approved by the party responsible for compliance could void the user's authority to operate the equipment.
- This product has been tested and complies with the specifications for a Class B digital device, pursuant to Part 15 of the FCC Rules. These limits are designed to provide reasonable protection against harmful interference in a residential installation.
- This equipment generates, uses, and can radiate radio frequency energy and, if not installed and used according to the instructions, may cause harmful interference to radio communications. However, there is no guarantee that interference will not occur in a particular installation.
- If this equipment does cause harmful interference to radio or television reception, which is found by turning the equipment off and on, the user is encouraged to try to correct the interference by one or more of the following measures:
 - Reorient or relocate the receiving antenna
 - Increase the separation between the equipment or devices
 - Connect the equipment to an outlet other than the receiver's
 - Consult a dealer or an experienced radio/TV technician for assistance.

Canada

The following information applies if you use the product within Canada area.

Innovation, Science and Economic Development Canada ICES statement

CAN ICES(B)/NMB(B)

European Union and United Kingdom



The following information applies if you use the product within the European Union and United Kingdom.

List of National Codes

COUNTRY	ISO 3166 2 LETTER CODE	COUNTRY	ISO 3166 2 LETTER CODE
Austria	AT	Liechtenstein	LI
Belgium	BE	Lithuania	LT
Bulgaria	BG	Luxembourg	LU
Croatia	HR	Malta	MT
Cyprus	CY	Netherlands	NL
Czech Republic	CZ	Norway	NO
Denmark	DK	Poland	PL
Estonia	EE	Portugal	PT
Finland	FI	Romania	RO
France	FR	Serbia	RS
Germany	DE	Slovakia	SK
Greece	GR	Slovenia	SI
Hungary	HU	Spain	ES
Iceland	IS	Sweden	SE
Ireland	IE	Switzerland	CH
Italy	IT	Turkey	TR
Latvia	LV	United Kingdom	GB

Safety Warnings

- Do NOT use this product near water, for example, in a wet basement or near a swimming pool.
- Do NOT expose your device to dampness, dust or corrosive liquids.
- Do NOT store things on the device.

- Do NOT obstruct the device ventilation slots as insufficient airflow may harm your device. For example, do not place the device in an enclosed space such as a box or on a very soft surface such as a bed or sofa.
- There is a remote risk of electric shock from lightning: (1) Do not use the device outside, and make sure all the connections are indoors. (For indoor devices only) (2) Do not install or service this device during a thunderstorm.
- Connect ONLY suitable accessories to the device.
- Do NOT open the device or unit. Opening or removing covers can expose you to dangerous high voltage points or other risks. Only qualified service personnel should service or disassemble this device. Please contact your vendor for further information.
- Make sure to connect the cables to the correct ports.
- Place connecting cables carefully so that no one will step on them or stumble over them.
- Always disconnect all cables from this device before servicing or disassembling.
- Do NOT remove the plug and connect it to a power outlet by itself; always attach the plug to the power adaptor first before connecting it to a power outlet.
- Do NOT allow anything to rest on the power adaptor or cord and do NOT place the product where anyone can walk on the power adaptor or cord.
- Please use the provided or designated connection cables/power cables/adaptors. Connect it to the right supply voltage (for example, 120V AC in North America or 230V AC in Europe). If the power adaptor or cord is damaged, it might cause electrocution. Remove it from the device and the power source, repairing the power adaptor or cord is prohibited. Contact your local vendor to order a new one.
- CAUTION: RISK OF EXPLOSION IF BATTERY IS REPLACED BY AN INCORRECT TYPE, DISPOSE OF USED BATTERIES ACCORDING TO THE INSTRUCTION. Dispose them at the applicable collection point for the recycling of electrical and electronic device. For detailed information about recycling of this product, please contact your local city office, your household waste disposal service or the store where you purchased the product.
- Use ONLY power wires of the appropriate wire gauge for your device. Connect it to a power supply of the correct voltage.
- The PoE (Power over Ethernet) devices that supply or receive power and their connected Ethernet cables must all be completely indoors.
- The following warning statements apply, where the disconnect device is not incorporated in the device or where the plug on the power supply cord is intended to serve as the disconnect device,
 - For PERMANENTLY CONNECTED DEVICES, a readily accessible disconnect device shall be incorporated external to the device;
 - For PLUGGABLE DEVICES, the socket-outlet shall be installed near the device and shall be easily accessible.
- If your device has an earthing screw (frame ground), connect the screw to a ground terminal using an appropriate AWG ground wire. Do this before you make other connections.
- If your device has no earthing screw, but has a 3-prong power plug, make sure to connect the plug to a 3-hole earthed socket.
- When connecting or disconnecting power to hot-pluggable power supplies, if offered with your system, observe the following guidelines:
 - Install the power supply before connecting the power cable to the power supply.
 - Unplug the power cable before removing the power supply.
 - If the system has multiple sources of power, disconnect power from the system by unplugging all power cables from the power supply.
- Do not put the device in a place that is humid, dusty or has extreme temperatures as these conditions may harm your device.

- Please refer to the device back label, datasheet, box specifications or catalog information for the power rating of the device and operating temperature.
- Do not leave a battery in an extremely high temperature environment or surroundings since it can result in an explosion or the leakage of flammable liquid or gas. (For devices with a battery)
- Do not subject a battery to extremely low air pressure since it may result in an explosion or the leakage of flammable liquid or gas. (For devices with a battery)
- Fuse Warning! Replace a fuse only with a fuse of the same type and rating. (For devices with a fuse)
- To avoid possible eye injury, do not look into an operating fiber-optic module's connector. (For devices with fiber)
- Complies with 21 CFR 1040.10 and 1040.11 except for conformance with IEC 60825-1 Ed. 3., as described in Laser Notice No. 56, dated May 8, 2019. (For devices with fiber)
- Conforme à 21 CFR 1040.10 et 1040.11 sauf pour la conformité à la norme CEI 60825-1 Ed. 3., comme décrit dans la notice laser Numéro 56 du 8 mai 2019. (For devices with fiber)
- CLASS 1 LASER PRODUCT & "IEC 60825-1:2014" (For devices with fiber)
- APPAREIL À LASER DE CLASS 1 (For devices with fiber)
- CLASS 1 CONSUMER LASER PRODUCT & "EN 50689:2021" (For devices with fiber)

Important Safety Instructions (For device with fan)

1 Warning! Energy Hazard. Remove all metal jewelry, watches, and so on from your hands and wrists before serving this device.

2 Caution! The RJ-45 jacks are not used for telephone line connection.

3  Hazardous Moving Parts. Keep body parts away from fan blades.

4  Hot Surface. Do not touch.

1 Avertissement: Risque de choc électrique. Retirer tout bijoux en métal et votre montre de vos mains et poignets avant de manipuler cet appareil.

2 Attention: Les câbles RJ-45 ne doivent pas être utilisés pour les connections téléphoniques.

3  Mobilité des pièces détachées. S'assurer que les pièces détachées ne sont pas en contact avec les pales du ventilateur.

4  Surface brûlante. Ne pas toucher.

Environment Statement

ErP (Energy-related Products)

All Zyxel products put on the EU and United Kingdom markets are in compliance with the requirement of the European Parliament and the Council published Directive 2009/125/EC and UK regulation establishing a framework for the setting of ecodesign requirements for energy-related products (recast), so called as "ErP Directive (Energy-related Products directive) as well as ecodesign requirement laid down in applicable implementing measures, power consumption has satisfied regulation requirements which are:

- Network standby power consumption < 8W and/or
- Off mode power consumption < 0.5W and/or
- Standby mode power consumption < 0.5W.

Disposal and Recycling Information

The symbol below means that according to local regulations your product and/or its battery shall be disposed of separately from domestic waste. If this product is end of life, take it to a recycling station designated by local authorities. At the time of disposal, the separate collection of your product and/or its battery will help save natural resources and ensure that the environment is sustainable development.

Die folgende Symbol bedeutet, dass Ihr Produkt und/oder seine Batterie gemäß den örtlichen Bestimmungen getrennt vom Hausmüll entsorgt werden muss. Wenden Sie sich an eine Recyclingstation, wenn dieses Produkt das Ende seiner Lebensdauer erreicht hat. Zum Zeitpunkt der Entsorgung wird die getrennte Sammlung von Produkt und/oder seiner Batterie dazu beitragen, natürliche Ressourcen zu sparen und die Umwelt und die menschliche Gesundheit zu schützen.

El símbolo de abajo indica que según las regulaciones locales, su producto y/o su batería deberán depositarse como basura separada de la doméstica. Cuando este producto alcance el final de su vida útil, llévelo a un punto limpio. Cuando llegue el momento de desechar el producto, la recogida por separado éste y/o su batería ayudará a salvar los recursos naturales y a proteger la salud humana y medioambiental.

Le symbole ci-dessous signifie que selon les réglementations locales votre produit et/ou sa batterie doivent être éliminés séparément des ordures ménagères. Lorsque ce produit atteint sa fin de vie, amenez-le à un centre de recyclage. Au moment de la mise au rebut, la collecte séparée de votre produit et/ou de sa batterie aidera à économiser les ressources naturelles et protéger l'environnement et la santé humaine.

Il simbolo sotto significa che secondo i regolamenti locali il vostro prodotto e/o batteria deve essere smaltito separatamente dai rifiuti domestici. Quando questo prodotto raggiunge la fine della vita di servizio portarlo a una stazione di riciclaggio. Al momento dello smaltimento, la raccolta separata del vostro prodotto e/o della sua batteria aiuta a risparmiare risorse naturali e a proteggere l'ambiente e la salute umana.

Symbolen innebär att enligt lokal lagstiftning ska produkten och/eller dess batteri kastas separat från hushållsavfallet. När den här produkten når slutet av sin livslängd ska du ta den till en återvinningsstation. Vid tiden för kasseringen bidrar du till en bättre miljö och mänsklig hälsa genom att göra dig av med den på ett återvinningsställe.



台灣

安全警告 – 為了您的安全，請先閱讀以下警告及指示：





- 請勿將此產品接近水、火焰或放置在高溫的環境。

- 避免設備接觸
 - 任何液體 - 切勿讓設備接觸水、雨水、高濕度、污水腐蝕性的液體或其他水份。
 - 灰塵及污物 - 切勿接觸灰塵、污物、沙土、食物或其他不合適的材料。
- 雷雨天氣時，不要安裝或維修此設備。有遭受電擊的風險。
- 切勿重摔或撞擊設備，並勿使用不正確的電源變壓器。
- 若接上不正確的電源變壓器會有爆炸的風險。
- 請勿隨意更換產品內的電池。
- 如果更換不正確之電池型式，會有爆炸的風險，請依製造商說明書處理使用過之電池。
- 請將廢電池丟棄在適當的電器或電子設備回收處。
- 請勿將設備解體。
- 請勿阻礙設備的散熱孔，空氣對流不足將會造成設備損害。
- 請使用隨貨提供或指定的連接線 / 電源線 / 電源變壓器，將其連接到合適的供應電壓 (如：台灣供應電壓 110 伏特) 。
- 假若電源變壓器或電源變壓器的纜線損壞，請從插座拔除，若您還繼續插電使用，會有觸電死亡的風險。
- 請勿試圖修理電源變壓器或電源變壓器的纜線，若有毀損，請直接聯絡您購買的店家，購買一個新的電源變壓器。
- 請勿將此設備安裝於室外，此設備僅適合放置於室內。
- 請勿隨一般垃圾丟棄。
- 請參閱產品背貼上的設備額定功率。
- 請參考產品型錄或是彩盒上的作業溫度。
- 設備必須接地，接地導線不允許被破壞或沒有適當安裝接地導線，如果不確定接地方式是否符合要求可聯繫相應的電氣檢驗機構檢驗。
- 如果您提供的系統中有提供熱插拔電源，連接或斷開電源請遵循以下指導原則：
 - 先連接電源線至設備連，再連接電源。
 - 先斷開電源再拔除連接至設備的電源線。
 - 如果系統有多個電源，需拔除所有連接至電源的電源線再關閉設備電源。
- 產品沒有斷電裝置或者採用電源線的插頭視為斷電裝置的一部分，以下警語將適用：
 - 對永久連接之設備，在設備外部須安裝可觸及之斷電裝置；
 - 對插接式之設備，插座必須接近安裝之地點而且是易於觸及的。

About the Symbols

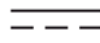
Various symbols are used in this product to ensure correct usage, to prevent danger to the user and others, and to prevent property damage. The meaning of these symbols are described below. It is important that you read these descriptions thoroughly and fully understand the contents.

Explanation of the Symbols

SYMBOL	EXPLANATION
	Alternating current (AC): AC is an electric current in which the flow of electric charge periodically reverses direction.
	Direct current (DC): DC is the unidirectional flow or movement of electric charge carriers.
	Earth; ground: A wiring terminal intended for connection of a Protective Earthing Conductor.
	Earth; ground: A wiring terminal intended for connection of a Functional Earthing Conductor.
	Class II equipment: The method of protection against electric shock in the case of class II equipment is either double insulation or reinforced insulation.

Viewing Certifications

Go to <http://www.zyxel.com> to view this product's documentation and certifications.

Zyxel Limited Warranty

Zyxel warrants to the original end user (purchaser) that this product is free from any defects in material or workmanship for a specific period (the Warranty Period) from the date of purchase. The Warranty Period varies by region. Check with your vendor and/or the authorized Zyxel local distributor for details about the Warranty Period of this product. During the warranty period, and upon proof of purchase, should the product have indications of failure due to faulty workmanship and/or materials, Zyxel will, at its discretion, repair or replace the defective products or components without charge for either parts or labor, and to whatever extent it shall deem necessary to restore the product or components to proper operating condition. Any replacement will consist of a new or re-manufactured functionally equivalent product of equal or higher value, and will be solely at the discretion of Zyxel. This warranty shall not apply if the product has been modified, misused, tampered with, damaged by an act of God, or subjected to abnormal working conditions.

Note

Repair or replacement, as provided under this warranty, is the exclusive remedy of the purchaser. This warranty is in lieu of all other warranties, express or implied, including any implied warranty of merchantability or fitness for a particular use or purpose. Zyxel shall in no event be held liable for indirect or consequential damages of any kind to the purchaser.

To obtain the services of this warranty, contact your vendor. You may also refer to the warranty policy for the region in which you bought the device at <https://www.zyxel.com/global/en/support/warranty-information>.

Registration

Register your product online at www.zyxel.com to receive email notices of firmware upgrades and related information.

Trademarks

The trademarks mentioned in this publication are used for identification purposes only and may be properties of their respective owners.

Numbers

10/100/1000 Mbps [9](#)

A

air circulation
 for cooling [14](#)
applications
 backbone [12](#)
 bridging [12](#)
 fiber uplink [12](#)
 PoE [11](#)
authorized technician
 install the Switch [14](#)
auto-MDIX port [23](#)

B

buffer memory
 overflow [51](#)

C

Cabling Length [64](#)
CE EMC statement [71](#)
certifications
 viewing [77, 84](#)
clearance
 Switch installation [14](#)
collision signal [51](#)
configuration
 restore [58](#)
contact information [65](#)
copyright [70](#)
CoS [11](#)

crossover Ethernet cable [23](#)
customer support [65](#)

D

Data path loop [64](#)
DHCP client [37, 57](#)
DHCP server [57](#)
disclaimer [70](#)
disposal and recycling information
 EU [74](#)
dual personality interface [26](#)
dust plug [25](#)

E

EEE [10, 22](#)
 REFRESH signal [56](#)
 WAKE signal [56](#)
electrical inspection authority [29](#)
electrician [29](#)
electrostatic discharge (ESD) [24](#)
Energy Efficient Ethernet [22](#)
 activate [58](#)
Energy Efficient Ethernet (EEE) [56](#)
Environment Statement [74, 81](#)
Ethernet
 connection speed [51](#)
Ethernet port
 auto-crossover [23](#)
 auto-negotiating [23](#)

F

Faulty cables [64](#)
FCC interference statement [70, 78](#)

Feature Comparison [9, 10](#)

fiber cable

connecting [25](#)

removal [26](#)

firmware upgrade [57, 58](#)

firmware version [47](#)

flow control [51](#)

frames

received [47](#)

transmitted [47](#)

freestanding installation

precautions [15](#)

front panel [21](#)

G

gateway [58](#)

gigabit ports [23](#)

grounding

for safety [27](#)

H

hardware installation [14](#)

hardware overview [21](#)

I

icon

logout [36](#)

IEEE 802.1Q tagged VLAN [53](#)

IEEE 802.3az [22](#)

IEEE 802.3az EEE [58](#)

IEEE 802.3x flow control [51](#)

initial setup

example [37](#)

tutorials [39](#)

Innovation, Science and Economic Development Canada

ICES statement [71, 79](#)

installation

air circulation [14](#)

desktop [15](#)

rack-mounting [18](#)

transceiver [24](#)

wall mounting [15](#)

installation requirements

rack-mounting [16](#)

installation scenarios [14](#)

IP address

assign [37](#)

change [37](#)

reset [36](#)

Switch [57](#)

IP routing domain [57](#)

IPv4 address [47](#)

L

LED Descriptions

LK/ACT [31, 32](#)

PWR [31](#)

login [33](#)

login account

administrator [56](#)

logout icon [36](#)

loop

detection [51](#)

prevention [49, 51](#)

loop status [48](#)

Low Power Idle [22](#)

Low Power Idle (LPI) mode [56](#)

LPI signal [22](#)

M

management method [11](#)

Management screen [37, 38, 56](#)

managing the Switch

good habits [13](#)

MDIX (Media Dependent Interface Crossover) [23](#)

mounting brackets [19](#)

Mounting Methods [14](#)

N

- navigation panel
 - links [35](#)
- network applications [11](#)
- network cable
 - crossover [21](#)
 - straight-through [21](#)
- Network Cable Types [22](#)
- Non-standard network cables [64](#)

O

- overheating
 - prevention [15](#)

P

- packet collision [51](#)
- password
 - change [38, 58](#)
 - forget [36](#)
 - keyboard characters [34](#)
 - set [38](#)
- PD [11](#)
- PD (Powered Devices) [42](#)
- PoE [9, 10, 11, 23, 30, 73, 80](#)
 - configuration [42](#)
- PoE power budget [47](#)
- PoE status (W) [48](#)
- port
 - advanced settings [51](#)
 - out-going [52](#)
 - tagged [55](#)
 - untagged [55](#)
 - uplink [49, 52](#)
- port isolation [49, 52](#)
- Port screen [50](#)
- port VID
 - set [40](#)
- port VLAN ID, see PVID [55](#)
- power connections [29](#)
- power connector [29](#)

- power saving [22](#)
- powered device [11](#)
- product registration [78, 85](#)
- PVID (Port VLAN ID) [40, 53, 55](#)

R

- rack-mounting [18](#)
 - installation requirements [19](#)
 - precautions [19](#)
- rear panel [26](#)
- registration
 - product [78, 85](#)
- Regulatory Notice and Statement [70](#)
- Reset button [36](#)
- resetting [36](#)
- Restore button [24](#)
- restoring configuration [36](#)
- rubber feet
 - attach [15](#)

S

- safety precautions
 - using the Switch [15](#)
- safety warnings [72, 79](#)
- screw anchors
 - using [17](#)
- SFP/SFP+ slot [24](#)
- Small Form-factor Pluggable (SFP) [24](#)
- Spanning Tree Protocol (STP) [49](#)
- status [35](#)
- straight-through Ethernet cable [23](#)
- subnet mask [57](#)
- Switch
 - fanless-type usage precaution [15](#)
 - fan-type usage precaution [15](#)
 - IP address [47, 57](#)
 - MAC address [47](#)
 - model name [47](#)
 - name [47](#)
 - reboot [57](#)
 - reset [36, 57](#)

- restart [57](#)
- return to factory defaults [57](#)
- subnet mask [47](#)
- up time [47](#)

Switch settings

- backup [58](#)

System screen [46](#)

T

- trademarks [78, 85](#)
- transceiver
 - connection speed [24](#)
 - installation [24](#)
 - removal [25](#)
- transceiver MultiSource Agreement (MSA) [24](#)
- transceivers [24](#)
- Troubleshooting
 - Improper Network Cabling and Topology [64](#)

U

- uplink connection
 - super-fast [12](#)

V

- ventilation holes [15](#)
- VID [55](#)
- VLAN
 - create [39, 55](#)
 - ID [55](#)
 - permanent member [40](#)
 - PVID [55](#)
 - tagged [53](#)
- VLAN 1 [39](#)
- VLAN screen [54](#)
- VLAN tag [40](#)
- VLAN-unaware device [40](#)

W

- wall mounting [15](#)
 - distance above the floor [16](#)
 - distance between holes [16](#)
- warranty
 - note [77, 84](#)
- Web Configurator
 - browser support [33](#)
 - home [35](#)
 - inactivity [36](#)
 - layout [35](#)
 - login [33](#)
 - logout [36](#)
 - navigation panel [35](#)
 - overview [33](#)
 - recommended screen resolution [33](#)